

PER RIDEN:
 --- Revised limit of disturbance.
 Install permanent buffer zone markers.
 Install additional *Pinus strobus* plantings.

DEPARTMENT OF ENVIRONMENTAL MANAGEMENT
 OFFICE OF WATER RESOURCES
 FRESHWATER WETLANDS PROGRAM
 APPROVED WITH CONDITIONS
 AS SPECIFIED IN THE LETTER OF APPROVAL
 DATED 11/12/2009 FILE # 08-0004
 NO CHANGES ALLOWED WITHOUT PRIOR APPROVAL
 APPROVED PLANS MUST BE AT CONSTRUCTION SITE.
Emgarten D. Wencel

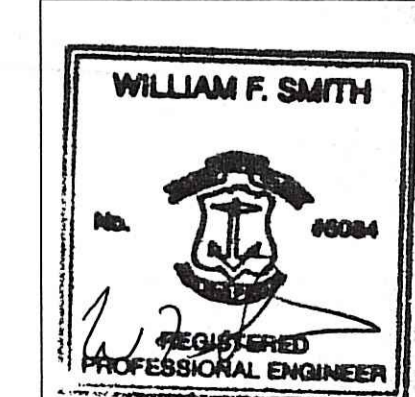
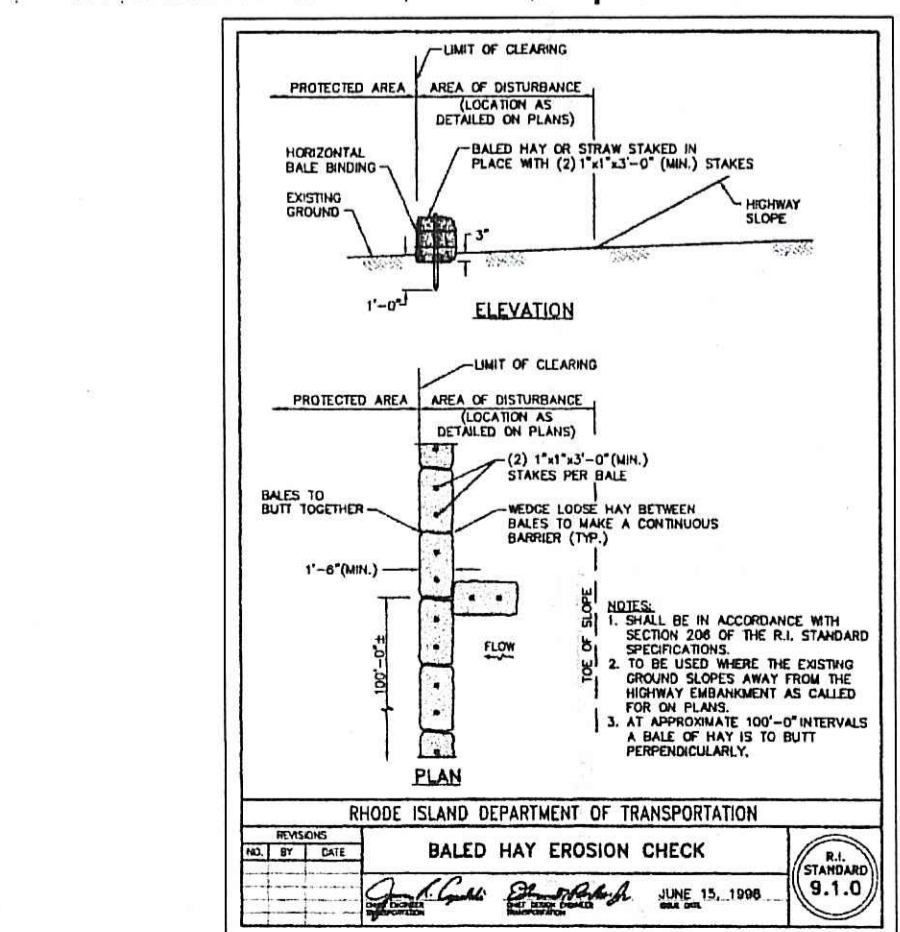
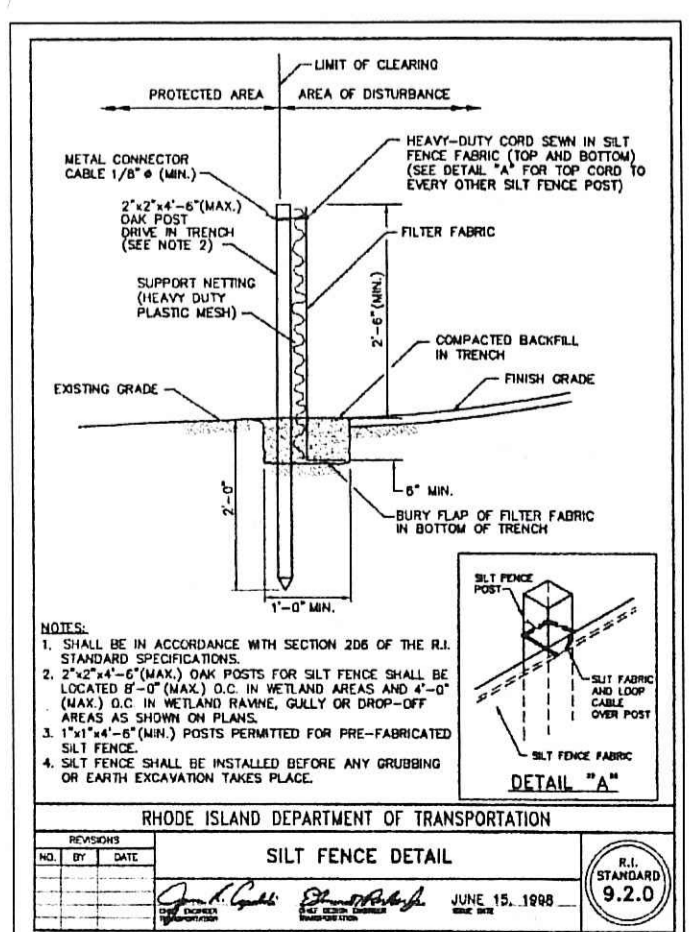
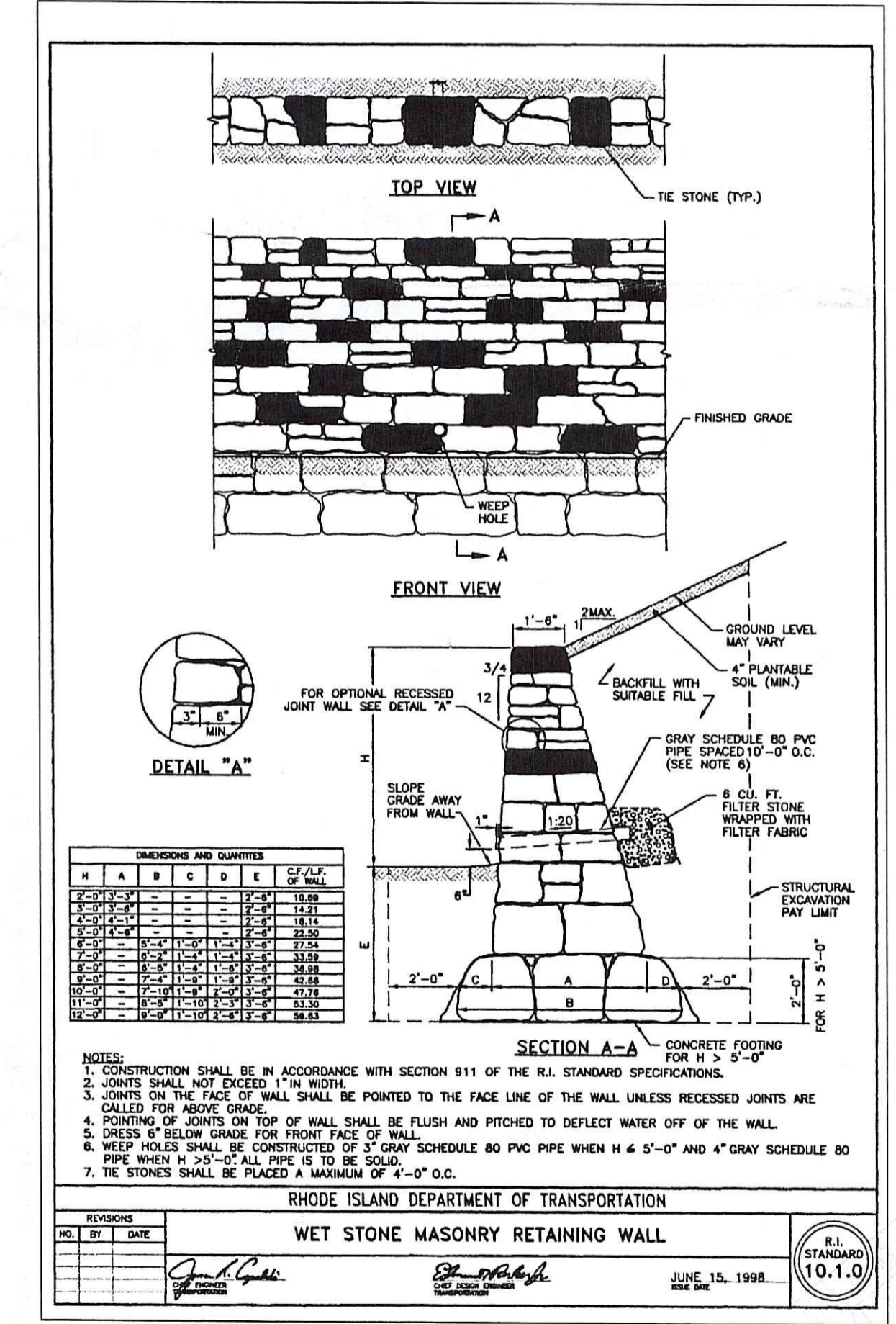

WETLANDS PERMIT / ISDS NEW CONSTRUCTION
 PREPARED FOR
INDIAN HEAD REALTY, INC.
 MAP 4-3 BLOCK 223 LOT 27
 WEST DEMELLO DRIVE
 TIVERTON, RHODE ISLAND
 SCALE: 1" = 20'
 DATE: FEBRUARY 8, 2008
Civil Engineering Concepts, Inc.
 34A MAIN STREET P.O. BOX 5323
 LITTLE COMPTON, RI 02837 NEW BEDFORD, MA 02742
 PH: (401) 592-0177 FAX: (401) 592-0178
 (508) 990-4900

PLAN FOR NOTICE

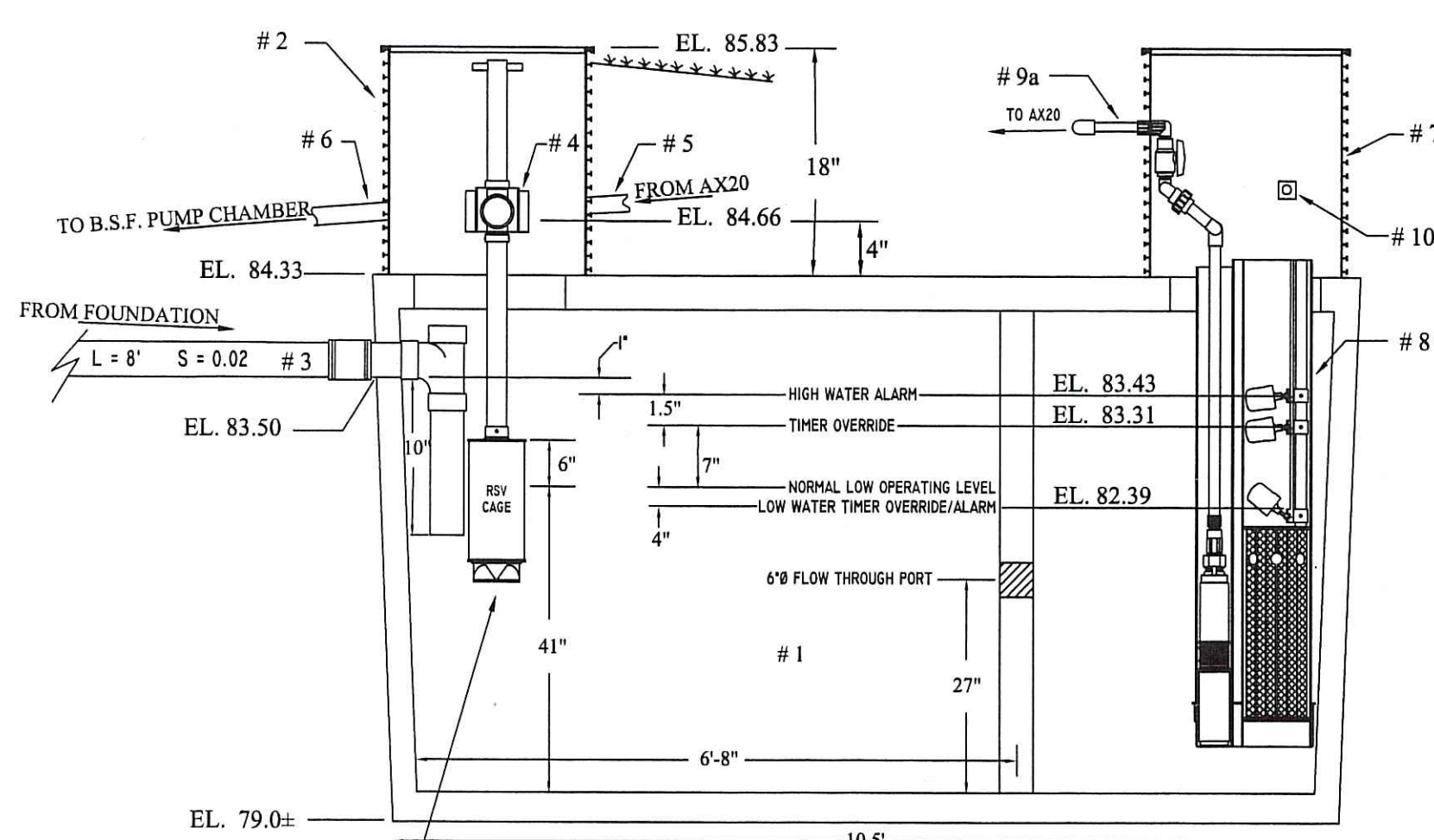

1500 GAL. PROCESSING TANK - PROFILE VIEW
R.S.V. ELEVATION AND FLOAT ELEVATIONS SHALL BE VERIFIED DURING START-UP TEST BY AN AUTHORIZED AGENT OF THE EQUIPMENT SUPPLIER.

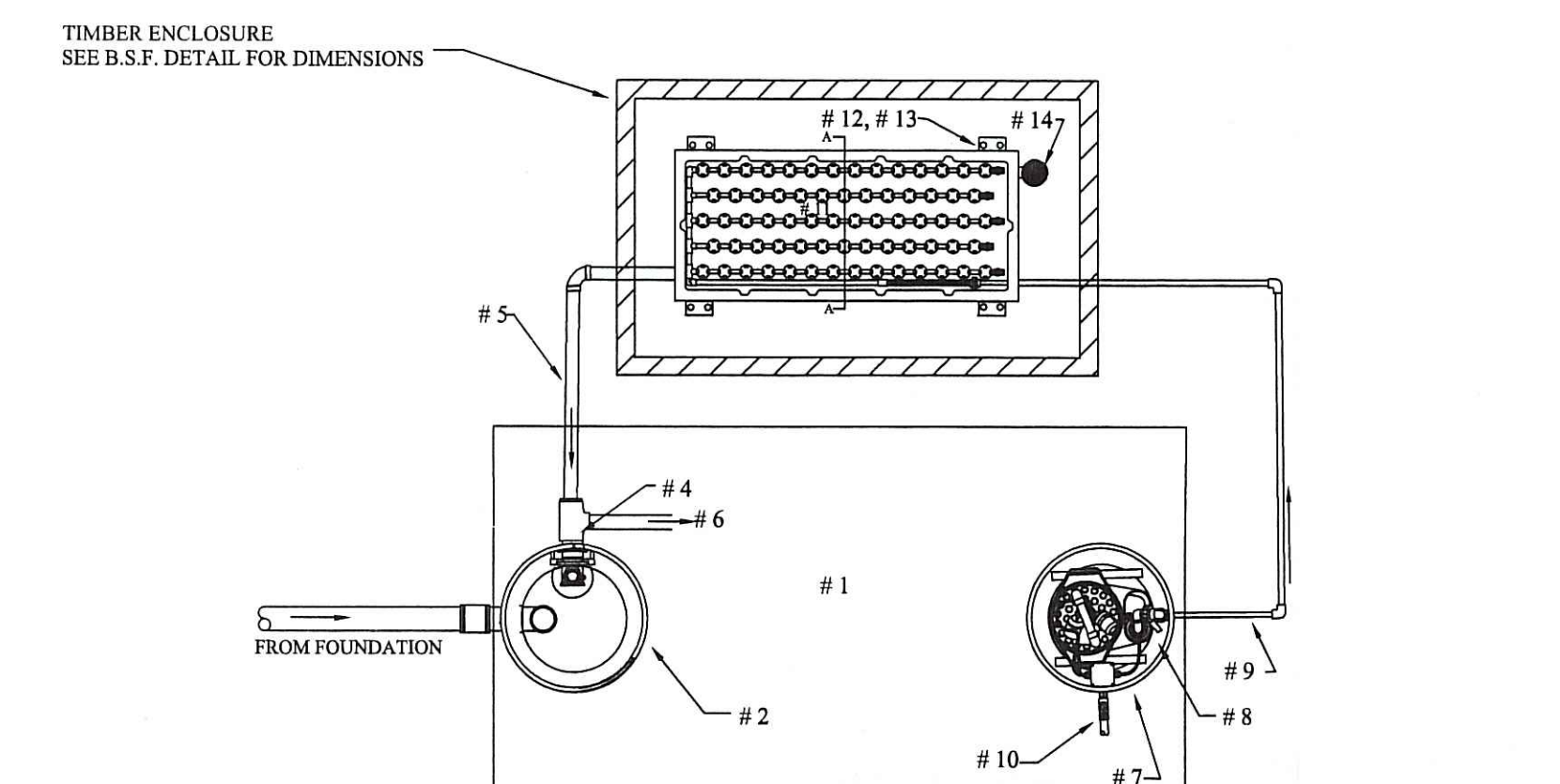

24" DIAMETER PVC PUMP CHAMBER - PROFILE VIEW

- PVC water tight basin w/ fiberglass cover
- Backfill material to be compacted (1' lifts) granular (sandy) fill
- 2" SCH-40 PVC (gravity) from R.S.V. Pressure rated fittings required, DWV fittings not permitted
- 2" x 2" x 2" SCH-40 tee with drop pipe extending to lowest float
- Finished grade to be 1" min. below cover
- Waterproof/vapor-proof PVC junction/splice box & elec. conduit
- SCH-40 reducer required: 1.5" to 1.25"
- Level Control Float Assembly - removable w/o entry into chamber
- "ALARM" Float
- "ON" Float
- "OFF" Float
- Discharge Transport piping: Class 200 psi (SCH-40) with pressure rated fittings - DWV fittings not permitted
- Threaded Disconnect - accessible from surface w/o chamber entry
- Drainback-type assembly required
- Fully ported Shut-off
- 3/16ths inch Weephole (directed away from floats)
- CONCRETE BALLAST REQUIRED - 12 CU. FT. (min)
- Checkvalve not required. Anti-siphon valve not required.
- OSI Effluent Pump: O.S.I. # PEF33

B.S.F. PUMP CHAMBER DETAIL
NOT TO SCALE

1500 GALLON PROCESSING TANK / AX20 MEDIA FILTER - PLAN VIEW
(Representative piping route - shown for component identification only. Refer to sheet 1 - Plan View for piping alignment)

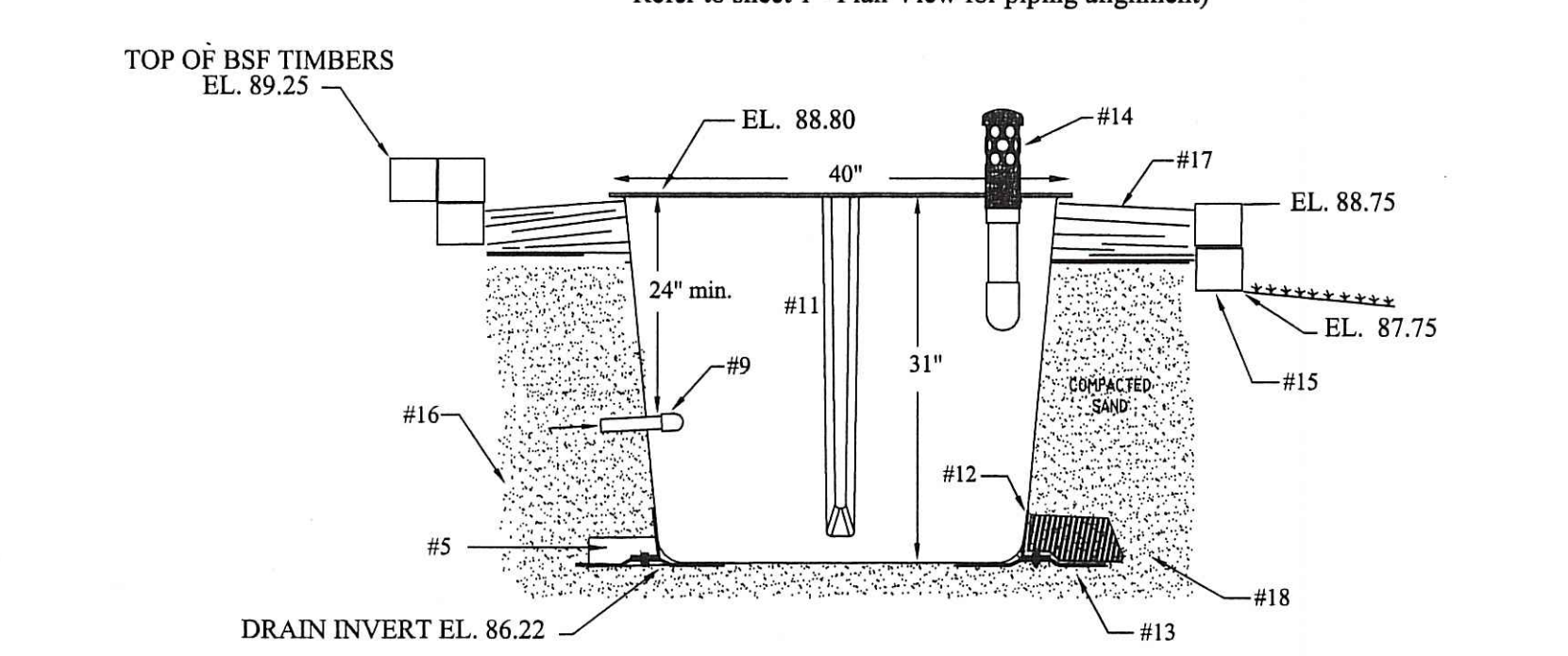

SECTION A-A ADVANTEK AX-20 FILTER

- 1500 gallon H-10 rated Processing Tank with baffle wall.
- 24" dia. OSI PVC inlet riser, w/ fiberglass bolt down cover, on watertight tank adapter.
- 4" SCH40 PVC building sewer pipe w/ inlet tee.
- Recirculation Splitter Valve (manufacturer specified).
- 2" SCH40 gravity pipe from AX20 pod to R.S.V.
- 2" SCH40 gravity pipe from R.S.V. to B.S.F. pump chamber.
- 24" dia. OSI PVC outlet riser, w/ fiberglass bolt down cover, on watertight tank adapter.
- OSI Biotube recirc. pump package w. OSI P3005, 1/2 hp, 1" discharge pump.
- 1" Class 200 (SCH40) PVC from Biotube AX pump to AX20 pod.
- Waterproof/vapor-proof electrical junction box.
- Advantek AX20 recirc. media Filter pod.
- Factory installed brackets (1 of 4).
- Contractor installed, factory provided, anti-floatation flanges (1 of 2).
- OSI passive air intake vent.
- 6" x 6" P.T. timber wall (same construction as B.S.F.).
- 5" layer of compacted clean granular (sand) material.
- 3" layer of mulch or pea gravel extending from top of compacted granular fill up to 1' below AX cover.
- 5 cu. ft. of poured concrete on each of two anti-floatation flanges.

PROCESSING TANK / ADVANTEK AX20 FILTER DETAILS
NOT TO SCALE

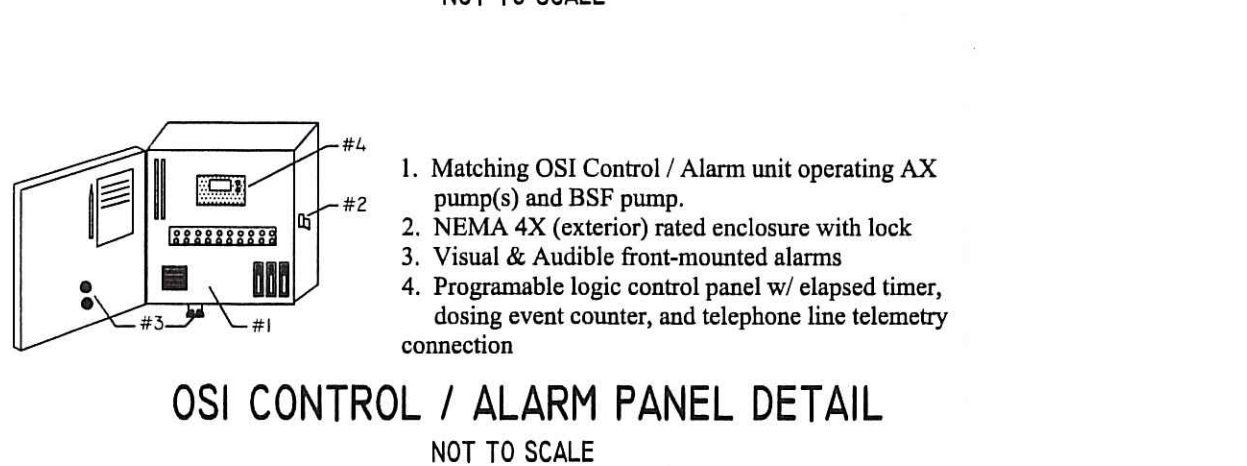

OSI CONTROL / ALARM PANEL DETAIL
NOT TO SCALE

87.75±...Top of Foundation
80.25...Basement floor (min) / walkout (east side)
83.66...Invert at foundation wall

86.0...Average Exist. Grade at Tank
82.5...Elevation of Waterable at Tank (42")
83.50...Inlet Invert at Tank

84.00...Inlet Invert at BSF Pump Chamber
84.00...Invert out of BSF Pump Chamber

89.25...Elevation of Top of Pea Stone
88.75...Invert of Distribution Lateral (laid level)
88.50...Top of C-33 Filter Sand
86.50...Bottom of C-33 Filter Sand
86.00...Bottom of 6" layer C-33 / Native Soil
84.75...Elev. of Water-Table at B.S.F. (42" below 3" of Organics)
88.5...Existing Average Grade at B.S.F.

88.75...Max. Prop. Grade Adjacent to BSF
87.25...Min. Prop. Grade Adjacent to BSF

ELEVATION SCHEDULE

NUMBER OF BEDROOMS: 3
DESIGN GALLONAGE: 450 gal/day
GARBAGE GRINDER: Not Allowed
LEACHING SYSTEM USED: Bottomless Sand Filter
SIZE OF PROCESSING TANK: 1500 gallons
SECONDARY TREATMENT UNIT: Advantek AX-20 Media Filter
SOIL TYPE: Friable SIL

APPLICATION RATE: Soil Category 7
BSF LOADING RATE: Use 2.8 gal/sf/day, timed dose category 1 L.R.

TOTAL SQUARE FOOTAGE REQ'D:
450 GAL/DAY = 160.8 S.F. REQUIRED
2.8 L.R. = 184.5 S.F. PROVIDED

BSF SQUARE FOOTAGE PROVIDED:
9'0" x 20'5" = 184.5 S.F. PROVIDED

BSF PUMP CHAMBER SIZE: 24" diameter, 6' deep
BSF DOSING CYCLE: 11" drawdown between "OFF" and "ON"
DOSING QUANTITY: 21.5 GALLONS/CYCLE

BSF DISCHARGE:
21.5 gal/cycle - 1.6 gal (drainback) / 84 orifices (per zone) = 0.24 GAL/ORIFICE/CYCLE

33.8 gpm (pump discharge) / 84 orifices = 0.40 GPM/ORIFICE

EMERGENCY STORAGE BELOW HIGH WATER ALARM: 21.5 GALLONS

BASIS OF SANITARY DESIGN

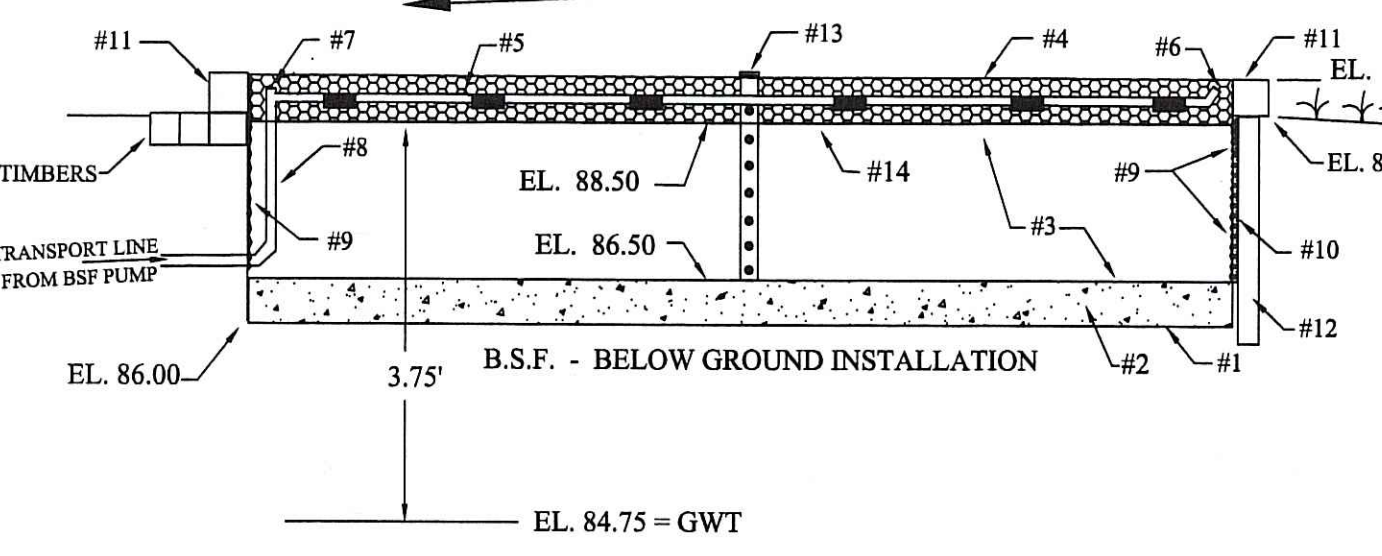

BOTTOMLESS SAND FILTER DETAILS
NOT TO SCALE

- Scarified and non-compacted native soil. Existing BSF ground surface preparation shall only consist of stripping native "A" and native "B" Horizons (if necessary) down to the specified elevation.
- 6" thick layer of evenly mixed Native Mineral Soil (from B Horizon) and ASTM C-33 Sand
- 24" minimum thick layer of non-compacted ASTM C-33 Sand
- 9" thick layer of 3/8ths inch Washed Pea Gravel
- Class 200 (SCH-40) PVC pipe with pressure rated fittings and orifices (with shields) spaced as specified in detail below.
- 45 elbow with threaded female cap (matching lateral diameter)
- Class 200 (SCH-40) PVC Manifold pipe
- Class 200 Transport pipe from BSF pump chamber.
- Installation sleeved over vertical portion of transport pipe inside BSF.
- Install "Tee" and threaded plug at 90-degree bend / connection to Manifold (allowing cleaning access to Transport pipe).
- 30 mil. PVC liner
- 1/2" non-PT plywood support frame below grade
- 6" x 6" PT timber support frame above ground
- 4" x 4" vertical non-PT vertical support timbers to brace 6" x 6" timber frame construction and plywood frame. Recommend 3 vertical timbers at each corner and every 10' o.c.
- 4" dia. filter fabric wrapped SDR-35 inspection well with removable cap 1/2 inch (min) dia. threaded tie rods required when 6" x 6" timbers exceed 2 courses min. in height. Refer to Bottomless Sand Filter note #28.
- 4" x 4" vertical non-PT vertical support timbers to brace 6" x 6" timber frame construction and plywood frame. Recommend 3 vertical timbers at each corner

- DISTRIBUTION LATERALS: shall be 0.75" dia. Class 200 (SCH-40) PVC with 1/8 inch orifices drilled at 18" o.c. at 6 o'clock position with orifice shields. 0.75" dia. 45-degree elbows with threaded female cap at distal ends required. Laterals slope down to the manifold.
- Two orifices per lateral, one at 1/3rd and one at 2/3rd distance from manifold, shall be located at the 12 o'clock position and fitted with an orifice shield on top to allow for proper drainage.
- TRANSPORT PIPE: shall be 1.25" Class 200 (SCH-40) pressure rated PVC piping.
- MANIFOLD: shall be 1.00" dia. Class 200 (SCH-40) pressure rated PVC pipe.

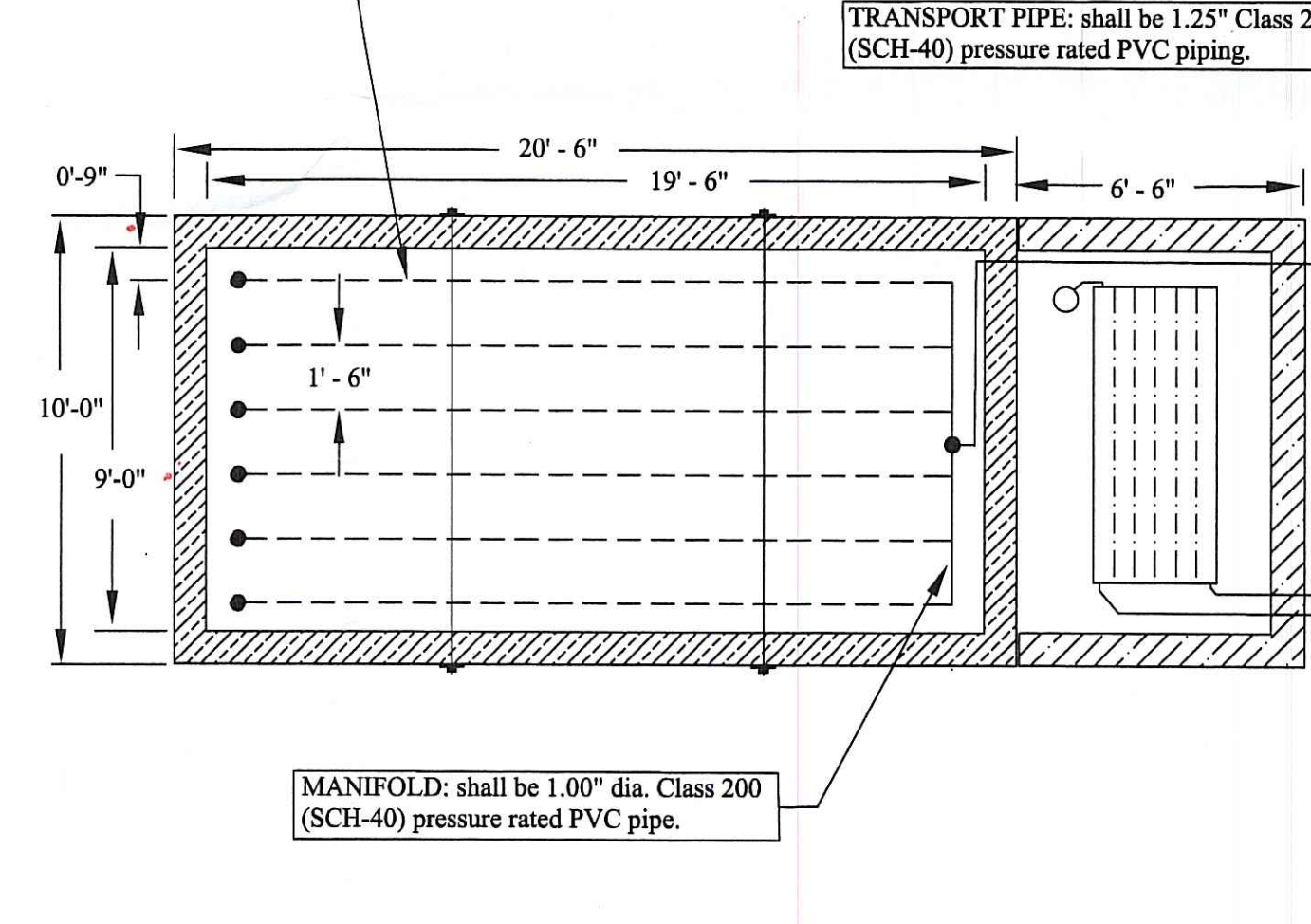

BOTTOMLESS SAND FILTER DETAILS
NOT TO SCALE

PROCESSING TANK
Tank type: 1500 Gallon H-20 Tank Wt.: 12,400 lbs.
Weight of Earth Cover (limited to 1.5' of soil on tank): 6,820 lbs.
Upward lift (neglecting soil friction): 10.5' (length) x 5.66' (width) x 3.6' (max. submerged depth) x 62.4 lbs/c.f. = 13,350 lbs.

Safety factor:
12,400 + 6,820 = 19,220
19,220 / 13,350 = 1.43

B.S.F. PUMP CHAMBER
Tank type: OSI 24" dia. PVC unit Tank Wt.: 200 lbs.
Weight of Earth Cover: 0 lbs.

Upward lift (neglecting soil friction):
Assume maximum water table at 1.5' below rim
1.0' x 1.0' x 3.14 x 4.5' x 62.4 lbs/c.f. = 882 lbs.

Concrete ballast required: 12 cu. ft. min.
12 cu. ft. x 87.6 lbs/c.f. (submerged conc. wt.) = 1051 lbs.

Safety factor:
200 + 1051 = 1251
1251 / 882 = 1.4

BUOYANCY CALCULATIONS

GENERAL CONSTRUCTION NOTES

- Designer recommends installing the septic system during dry months (June-October) to avoid complications with a high water table or excessive surface water runoff during construction. A high water table or saturated ground conditions during construction activities could compromise the quality and life expectancy of the system.
- All construction shall conform to the State of Rhode Island and Providence Plantations Department of Environmental Management - Rules and Regulations Establishing Minimum Standards relating to location, design, construction, and maintenance of Individual Sewage Disposal Systems as most recently amended, and in accordance with the Bottomless Sand Filter Guidelines Document (as most recently amended).
- All work shall be done in a worklike manner with lines laid as straight as possible and joints made watertight. All work shall be performed by an Installer licensed in the State of Rhode Island and certified for the installation of B.S.F. - type systems by RIDEM and the Vendor. Verification of Installer's certification may be required by the Designer prior to "start of construction" request by the Installer.
- Designer is to be notified 72 hours prior to the start of ISDS construction. Contractor is to ensure that Designer is notified 2 working days in advance of any required inspections so proper notification to RIDEM can be made. Work shall not continue until the previous stage is inspected and approved.
- Contractor or homeowner shall provide the designer with a copy of the recorded Maintenance Agreement prior to the Designer's issuance of Certificate of Construction.
- Dig-Safe notification is required prior to any excavation. Any underground utilities shown area approximate only and are based on limited availability of plans, visual observation, and local knowledge. Actual locations are to be verified by the Contractor prior to excavation through Dig-Safe procedures and any local utility department as necessary.
- Area to be utilized for the B.S.F. shall remain clear of all vehicles, equipment, and stockpiles materials. Contractor shall delineate the B.S.F. area with caution tape to restrict access. Compaction or smearing of native soil will compromise the operation of the B.S.F.
- Proper size hole saws, in good conditions, are to be used for the installation of conduit/piping grommets. Refer to, and follow, required hole sizes specified in manufacturer's installation documentation. The use of incorrectly sized hole saw will result in improperly seated grommets. Any conduit/piping installed into polyethylene riser or tank that is not watertight will not be approved by the Designer.

- SEPTIC/RECIRCULATION TANK: Gallonage as specified on Processing Tank Detail
- Equipped with suitable cast-in-place PVC mounting flange for detail-specified diameter inlet & outlet PVC risers. Watertight bonding epoxy (or other proper adhesive) required between tank adapters and risers. Access covers are not to be covered with soil. Final loam placement (elevation) shall be at least 1' below the access covers and graded away from the tank to prevent surface water from ponding on and entering the covers.
 - All tank seams, riser connections (if any) and all plumbing joints are to be installed 100% watertight, sealed with suitable gasket material, or other bonding agent suitable for that specific component. Any knock-out holes in the bottom of the tank shall remain sealed with suitable plug and hydraulic cement. Unused inlet/outlet knock-outs shall be sealed with hydraulic cement. Static water test required on the tank following attachment of risers. The life span of the system would be compromised by the intrusion of any groundwater.
 - Manufacturer's mounting hardware shall be utilized. All materials and construction shall meet the manufacturer requirements and applicable building, plumbing, electrical, and safety codes. Third party or alternate generic parts requiring substantial field modifications to fit shall not be permitted.
 - For additional pump information, see details contained within this plan, accompanying documentation and manufacturers published information provided at the time of pump purchase. The information contained within this plan is intended to provide schematic requirements only. Actual manufacturer's shop drawings are to be coordinated with the component supplier, including all accessories such as alarms, floats, etc. that are compatible with the pumps. Odd components requiring extensive modification to the system are not permitted.
 - A sign shall be posted in the vicinity of pump manholes warning of the potential of hazardous sewer gases and the need for proper confined space entry, venting, and air monitoring prior to working on the pump assembly.
 - Electrical wiring is to be encased in suitable conduit with proper fittings at each end to maintain a waterproof connection and prevent transport of vapors/gas from the components to the control panel and building. Electrical installation shall conform to all applicable local/state regulations.
- ADVANTEK AS RECIRCULATING MEDIA FILTER:
- The AX pod shall be laid level on a 5" (min) thick bed of compacted sand/gravel. When installed above the processing tank, it is recommended that a frame of non-P.T. 2" x 6" lumber be constructed on top of the processing tank to support the sand/gravel, preventing material washout from under the AX pod.
 - Proper compaction of well-drained granular material under, along side, and above the four anti-floatation flanges is necessary to ensure the pod will not float. If concrete ballast is specified on plan, compacted material under and along side of the flanges is required to support the concrete.
 - Manufacturer's mounting hardware shall be utilized. All materials and construction shall meet the manufacturer requirements and applicable building, plumbing, electrical, and safety codes. Third party or alternate generic parts requiring substantial field modifications to fit shall not be permitted.
 - For additional pump information, see details contained within this plan, accompanying documentation and manufacturers published information provided at the time of pump purchase. The information contained within this plan is intended to provide schematic requirements only. Actual manufacturer's shop drawings are to be coordinated with the component supplier, including all accessories such as alarms, floats, etc. that are compatible with the pumps. Odd components requiring extensive modification to the system are not permitted.
 - A sign shall be posted in the vicinity of pump manholes warning of the potential of hazardous sewer gases and the need for proper confined space entry, venting, and air monitoring prior to working on the pump assembly.
 - Electrical wiring is to be encased in suitable conduit with proper fittings at each end to maintain a waterproof connection and prevent transport of vapors/gas from the components to the control panel and building. Electrical installation shall conform to all applicable local/state regulations.

- B.S.F. PUMP SYSTEM:
- OSI 6" deep PVC pump chamber. Any weepholes shown shall not be directed toward floats. Pump floats shall be controlled by the septic/recirculation tank Biotube Pump Vault Control Panel. Discharge piping shall be equipped with an anti-siphon valve only when the B.S.F. is located below the pump chamber "OFF" float elevation. Final loam placement (elevation) shall be at least 1' below the fiberglass/PVC access cover and graded away from chamber to prevent surface water from ponding on and entering the cover.
 - Transport line shall be Class 200 (SCH-40) pressure piping (with pressure rated fittings) laid at consistent slope up to the B.S.F. allowing drainback, unless entire transport pipe is laid a minimum 3' deep below finished grade. A minimum of 15' earth cover over pipe is required unless insulation is specified. Transport pipe shall be threaded onto pump basin's flexible discharge pipes. 1 cu. ft. (min) concrete thrust blocks required at all angle points.
 - B.S.F. pump(s) shall be as specified. Any pump substitution shall require the Designer's review of the substitute pump specifications and pump curve.
 - B.S.F. pump calculations input data/pump curve is provided on attachment with application. Lateral lengths & manifold lengths used for pump specifications reflect that piping does not extend to the far edges of the B.S.F. filter box.

- ELECTRICAL CONTROL/ALARM PANEL: w/ telephone line remote telemetry connection
- Control Panel shall be an OSI pump-matched NEMA-4 rated waterproof lockable unit with visual alarms and programmable timer that operates both OSI AX Media Filter pump unit and B.S.F. pump on same circuit.
 - Panel to be mounted adjacent to exterior wall of the building within view of the tanks. Outside face of Control Panel shall be equipped with high-intensity alarm light and alarm silence button that shall automatically reactivate after 12 hours.
 - A start up test is required to be performed by the Installer/Maintenance provider and witnessed by the Designer of the AX pumping system, the B.S.F. pumping system, and the pressure (head) testing of the B.S.F. laterals. Any subsequent electrical work shall include the Electrician's verification that the electricity is properly restored to the Control Panel.
- BOTTOMLESS SAND FILTER (B.S.F.):
- B.S.F. shall be constructed as shown with materials as specified in the details. Installation of a 4" dia. perforated (filter fabric wrapped) inspection well required.
 - Sand media material shall conform to ASTM C33 sand (sieve) requirements with less than 1% fines passing number 200 sieve. Bank run sand or conventional ISDS sand/gravel is not permitted. Designer may require sieve analysis from sand supplier within 3 days prior to sand delivery.
 - Manifold: dia. as specified on detail and shall be Class 200 (SCH-40) PVC. All fitting shall be pressure rated (DWV fittings not recommended).
 - Distribution lateral: dia. specified on detail and shall be Class 200 (SCH-40) PVC with 1/8" orifice holes (drilled with a new bit) and fitted standard cold weather orifice shields spaced at intervals specified. Laterals shall be laid level. Distal ends of laterals shall be equipped with a 45-degree elbow and 3/4" or 1" threaded female end cap. Sweep elbows extending to the surface are not to be installed on ends. All fittings shall be pressure rated (DWV fittings not acceptable).
 - Leaching area excavation shall be level and scarified as shown on B.S.F. cross-section detail. Care shall be taken to avoid compaction of remaining soil. Excavation of native material below the B.S.F. shall only be to the extent designated on the plan. Where the B.S.F. is located completely above ground, material removal shall only consist of stripping grass/thatch layer and A horizon. Prepared native soil surface (bottom inspection) shall be inspected by the Designer prior to placement of 6" thick layer of sand/soil mix.
 - Above ground B.S.F. support framing shall consist of 6" x 6" pressure treated timbers drilled and pinned to the soil with #3 #4 rebar and screwed/nailed together at the corners and joints. Below ground construction shall utilize 1/2" min. thickness P.T. plywood in place of timbers. 30 mil. liner shall be placed inside timbers and plywood. Vertical 4" x 4" timbers (to support 6" x 6" frame) required with three at each corner and one every 10' on center. (max).
 - Where more than two courses of 6" x 6" timbers are exposed, 1/2" dia. threaded galvanized rod(s) with 2" dia. galvanized washers and nuts shall be installed in the second timber down from the top (to support timbers from bowing out), evenly placed along the length of B.S.F. (approximately 12' o.c.).
 - Trees or shrubs shall not be planted within 10' of the B.S.F. without vertical placement of a suitable root barrier fabric installed at least 3' beyond the B.S.F. and extending from 4' below finished grade to 1' below the bottom of the native soil/B.S.F. sand interface.
 - Heavy equipment shall not be operated over the components or the prepared leaching area during installation. Rubber tired machinery is not to be driven over the prepared natural soil base or sand/stone bed during system installation.
 - B.S.F. is not to be covered with topsoil or any other type of cover material that will restrict air flow. Any accumulated weeds, grass, or foreign material on the filter shall be removed by hand labor. Pea gravel surface must remain fully exposed to atmosphere.
 - All existing or proposed (if any) wells within 200' of proposed ISDS.
 - All existing or proposed (if any) public wells within 500' of proposed ISDS are shown.
 - All existing or proposed septic systems within 100' of the proposed on-site well are shown.
 - No parking is permitted in the vicinity of the ISDS.
 - No drains allowed within 25' of proposed ISDS.
 - A backup generator (adequate for supplying the pumps in case of electrical failure) is strongly recommended.
 - Property lines as depicted on this plan are approximate only based on Assessor Tax Maps and are not the result of a boundary survey.
 - For proper operation, the septic tank shall be inspected annually and pumped when any solids accumulation exceeds 1/3rd liquid depth.
 - A manufacturer-approved maintenance contract for the pump/filter system is required to be filed in the applicable Town Hall Land Evidence records office. Contract must be kept current as a condition of approval.

DEPARTMENT OF ENVIRONMENTAL MANAGEMENT
OFFICE OF WATER RESOURCES
FRESHWATER WETLANDS PROGRAM
APPROVED WITH CONDITIONS
AS SPECIFIED IN THE LETTER OF APPROVAL
DATED July 20, 2007 FILE # 08-0054
NO CHANGES ALLOWED WITHOUT PRIOR APPROVAL
APPROVED PLANS MUST BE AT CONSTRUCTION SITE.

WETLANDS PERMIT / ISDS NEW CONSTRUCTION - DETAILS
PREPARED FOR
INDIAN HEAD REALTY, INC.
MAP 4-3 BLOCK 223 LOT 27
WEST DEMELLO DRIVE
TIVERTON, RHODE ISLAND

SCALE: NONE DATE: FEBRUARY 8, 2008

Civil Engineering Concepts, Inc.
34-A MAIN STREET
LITTLE COMPTON, RI 02837
PH: (401) 592-0177
FAX: (401) 592-0178

P.O. BOX 5323
NEW BEDFORD, MA. 02742
(508) 990-4900

SHEET 2 OF 2 JOB#: 05-070-27

REVISIONS:

WILLIAM F. SMITH
REGISTERED PROFESSIONAL ENGINEER