

NARRAGANSETT ENGINEERING INC.

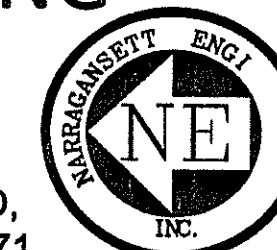

MAIN OFFICE:
3102 EAST MAIN ROAD,
PORTSMOUTH, RI 02871
TEL : (401) 683-6630

www.nei-cds.com

PROPOSED TRUCK PARKING LOADING AREA PLAN

OWNER OF RECORD
SKN ASSOCIATES LLC
20 BELMOUNT DRIVE,
PORTSMOUTH, RI 02871
C/O
NAPA AUTO PARTS
15 VALLEY RD
MIDDLETOWN, RI 02842

LOCATION
15 VALLEY ROAD,
MIDDLETOWN, RI 02842

PLAT: 107NE LOT: 35



APPROVED WITH CONDITIONS
AS SPECIFIED IN THE LETTER OF APPROVAL
DATED JUN 10 2010 FILE # 10-0095
NO CHANGES ALLOWED WITHOUT PRIOR APPROVAL
APPROVED PLANS MUST BE ON CONSTRUCTION SITE

PROJECT #	DATE	DRAWN	CHECK
10.0138	05-05-10	BVK	SLA

NO.	DATE	DESCRIPTION	BY



LOCUS	
SHEET	SCALE
1 OF 1	1" = 40'

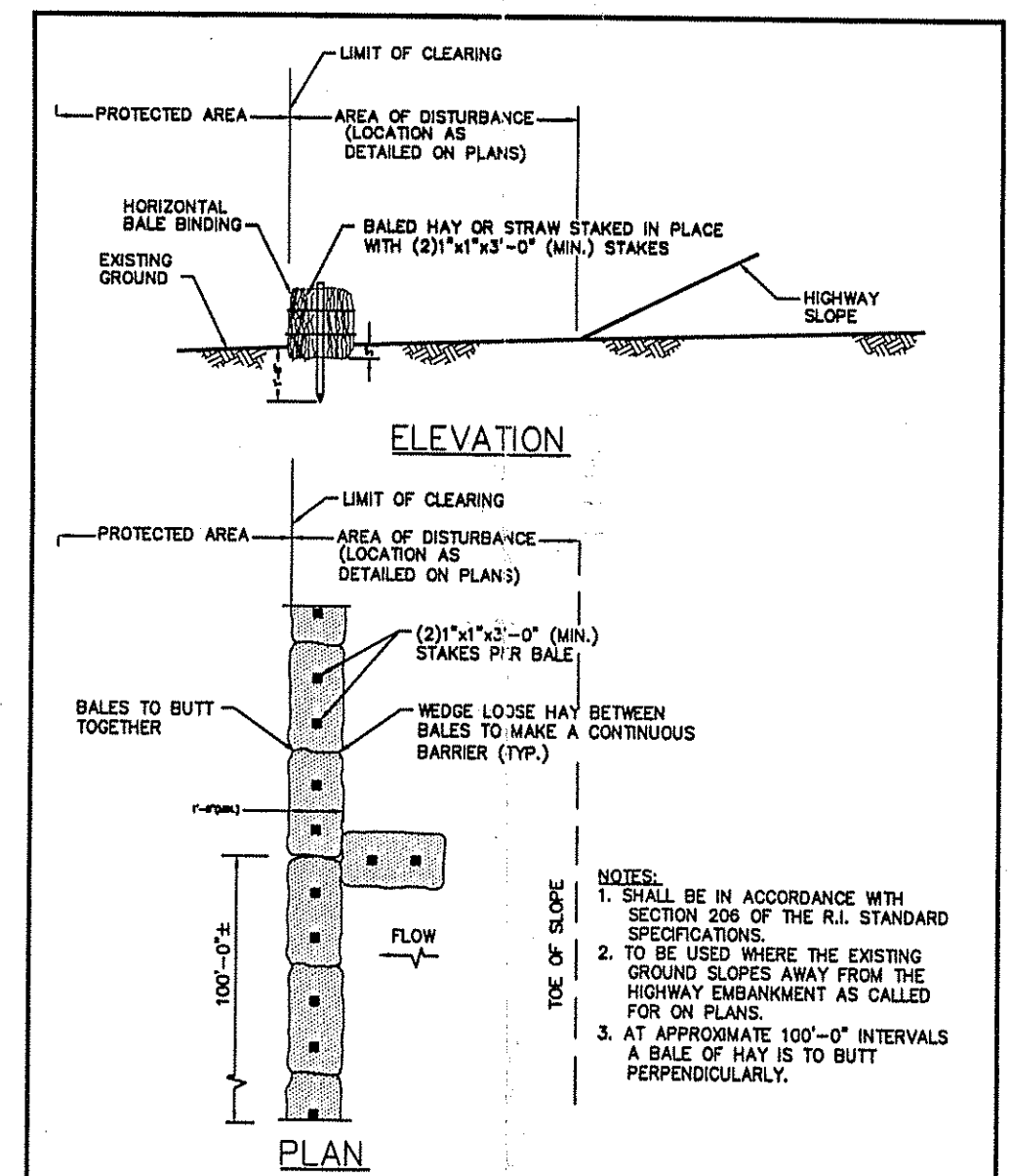
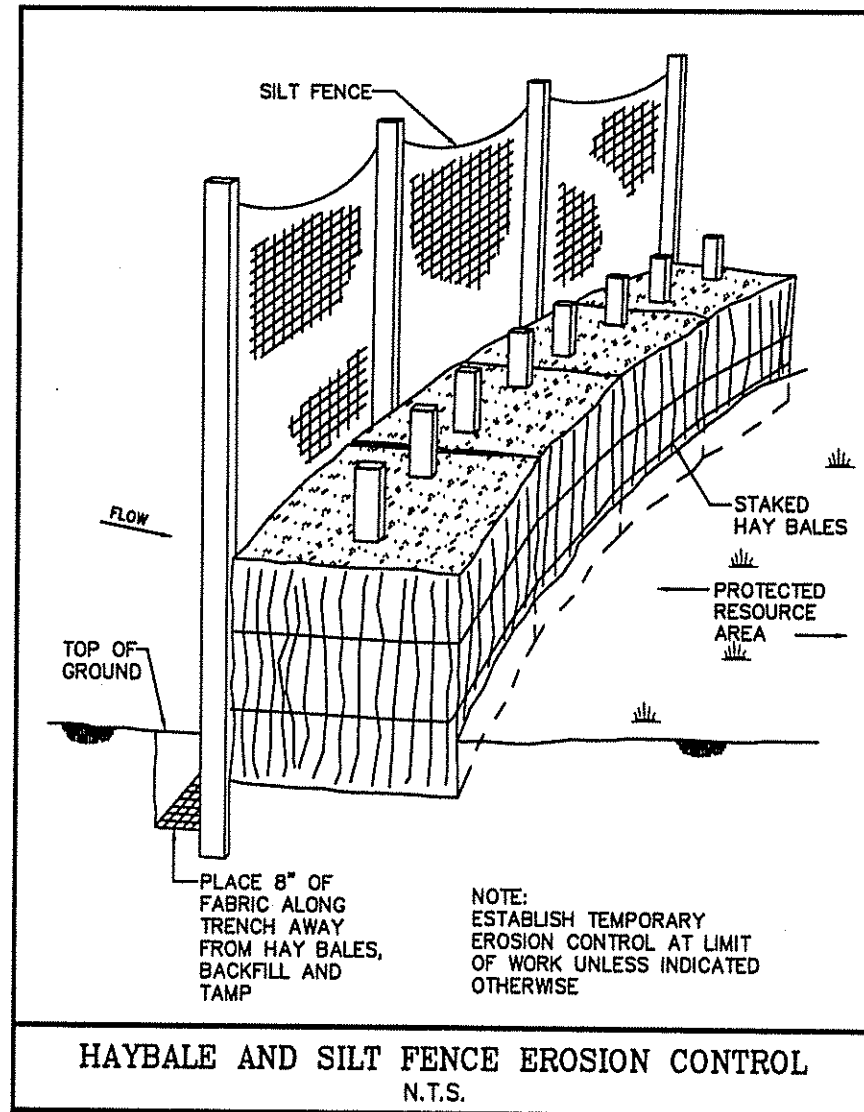
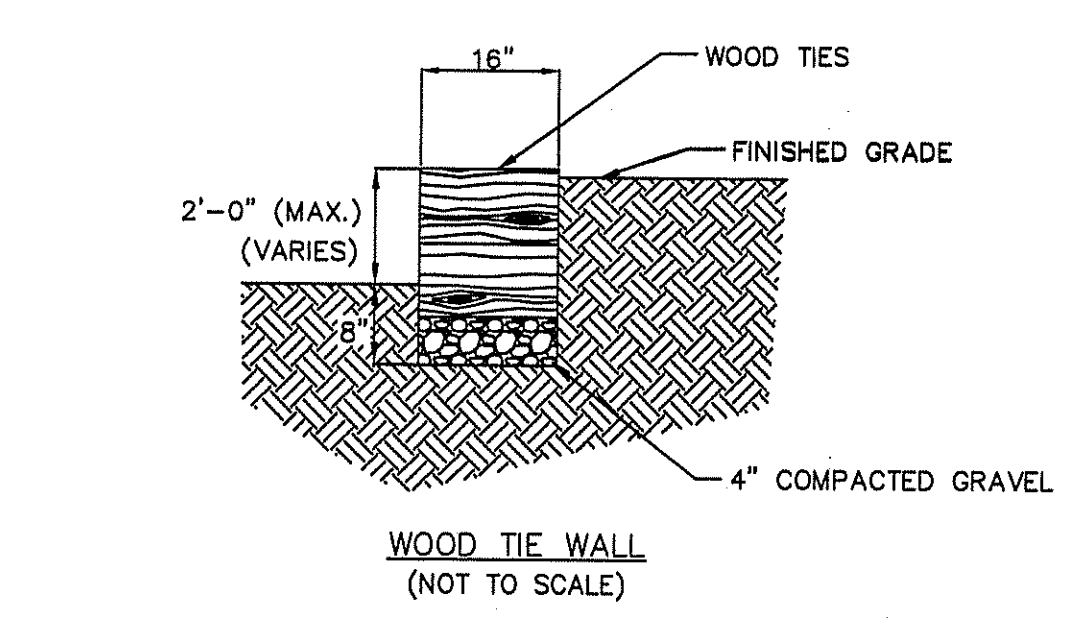
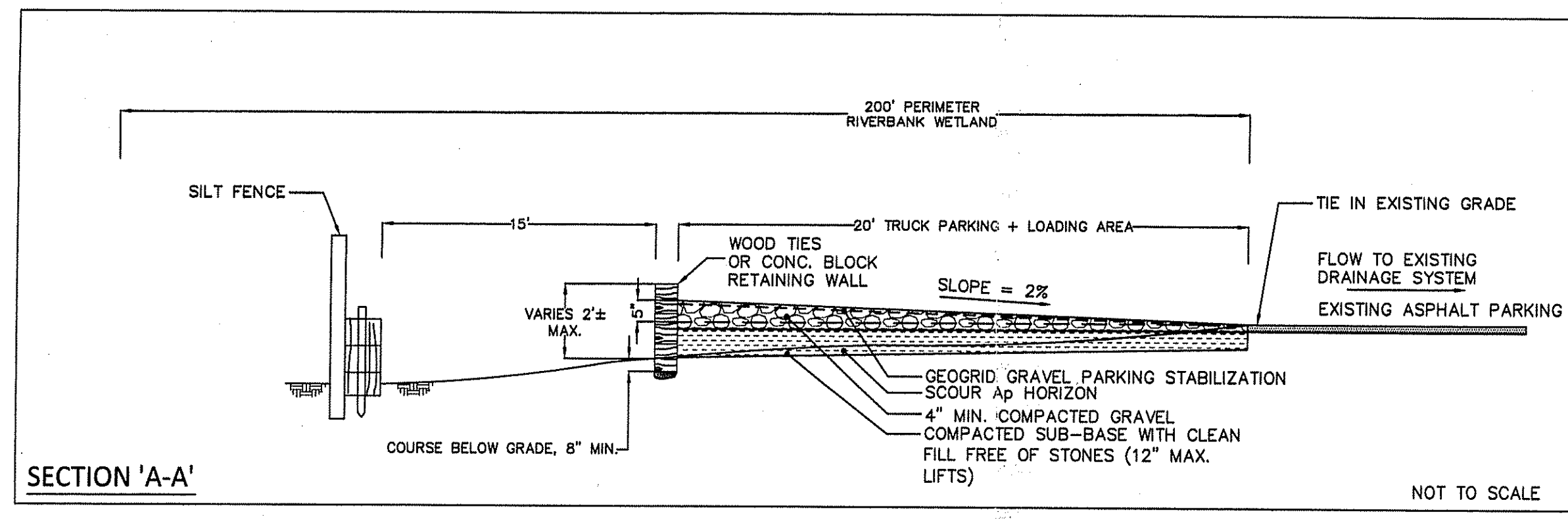

RHODE ISLAND DEPARTMENT OF TRANSPORTATION

NO.	DATE	DESCRIPTION

BAILED HAY EROSION CHECK

JUNE 15, 1998

R.I. STANDARD 9.1.0

NOTES:
-TOTAL LOT AREA: 3.59± ACRES.
-DATUM IS LOCAL
-MAINTAIN EXISTING DRAINAGE PATTERNS
-NO INCREASE IN IMPERVIOUS AREA.
-PROPERTY LINE SURVEY NOT PERFORMED, PROPERTY INFORMATION FROM EXISTING RECORD PLANS

ZONING REQUIREMENTS:
ZONE: OBA (TRAFFIC SENSITIVE OFFICE BUSINESS)
PARTIALLY WITHIN WATERSHED PROTECTION DISTRICT 1 AND 2
MINIMUM LOT AREA: 12,000 SQUARE FEET
MINIMUM LOT WIDTH: 300 FEET

MINIMUM SETBACKS:
FRONT YARD: 50 FEET
SIDE YARD: 10 FEET
REAR YARD: 20 FEET
MAXIMUM HEIGHT OF PRINCIPLE BUILDING: 40 FEET
MAXIMUM HEIGHT OF ACCESSORY BUILDING: 20 FEET
BUILDING COVERAGE: 25%

FLOOD ZONE:
-SUBJECT PROPERTY IS LOCATED IN FLOOD ZONES "AE" (ELEVATION 56.00) AND ZONE "X" AS PER FLOOD INSURANCE RATE MAP, PANEL 93 OF 226 FEMA COMMUNITY PANEL NO: 44005C0093H, DATED APRIL 5, 2010.

LEGEND:

	PROPERTY LINE
	EDGE OF PAVEMENT
	EXISTING CONTOUR
	PROPOSED CONTOUR
	ABUTTING LOT LINE
	EXISTING FENCE
	EDGE OF STREAM
	200' RIVER PERIMETER
	20' WIDE SANITARY SEWER EASEMENT
	25' WIDE ACCESS AND UTILITY EASEMENT
	LAWN EDGE
	EXISTING SANITARY LINE
	SILT FENCE
	LIMIT OF DISTURBANCE
	HANDICAP PARKING
	PROPOSED GRADE
	EXISTING GRADE

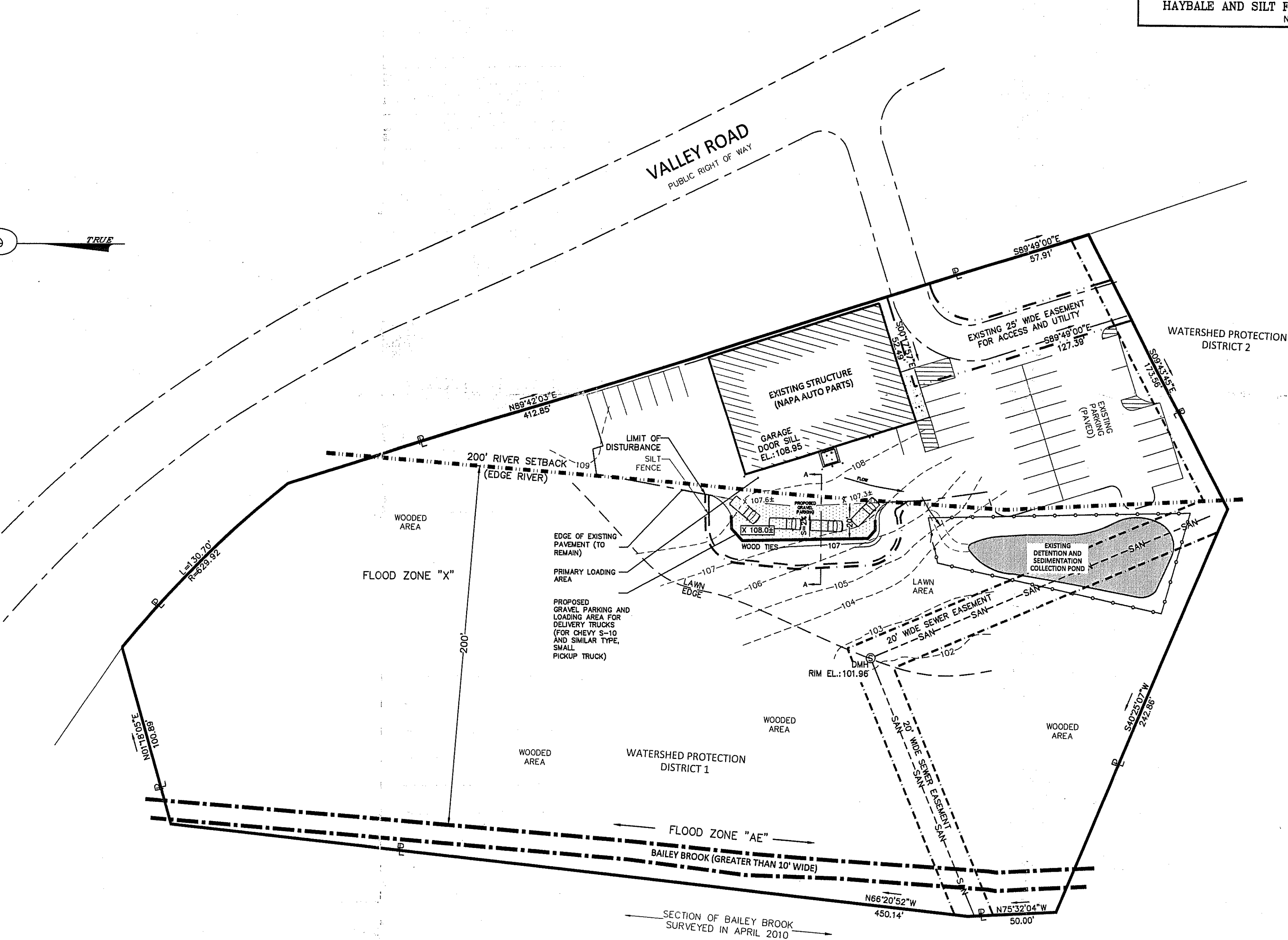
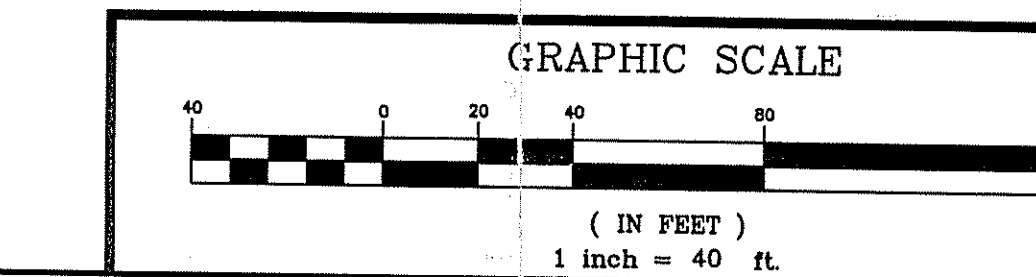

LOCATION OF SUBSURFACE UTILITIES REPRODUCED FROM FIELD SURVEY AND BEST AVAILABLE INFORMATION. CONTRACTOR TO CALL DIG SAFE AND/OR APPLICABLE UTILITY COMPANIES PRIOR TO ANY CONSTRUCTION.
DIG SAFE TEL.#: 1-800-344-7233 (1-800-DIG-SAFE).