

FED. ROAD DIST. NO.	STATE	FEDERAL AID PROJECT NO.	FISCAL YEAR	SHEET NO.	TOTAL SHEETS
	RI		2018	1	11

# INDEX

SHEET NO.	DESCRIPTION
1	COVER SHEET
2	LEGENDS & CALLOUTS
3	GENERAL NOTES
4	SITE 7A - LAYOUT & GRADING PLAN
5	SITE 7B - LAYOUT & GRADING PLAN
6	CONSTRUCTION ACCESS MAP
7	DETAILS (1)
8	DETAILS (2)
9	SIZING CALCULATIONS
10	SITE 7A - LANDSCAPE PLAN
11	SITE 7B - LANDSCAPE PLAN

STATE OF RHODE ISLAND

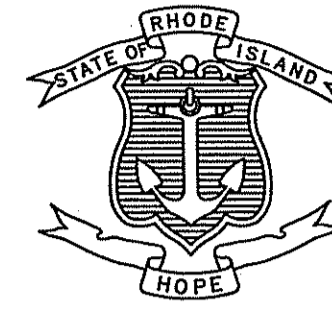

DEPARTMENT OF TRANSPORTATION

PLAN, PROFILE AND SECTIONS OF PROPOSED

STATE HIGHWAY

STORMWATER RETROFITS

ROGER WILLIAMS PARK – SITE 7A & 7B

ELMWOOD AVENUE ON AND OFF RAMP OF EXIT 1 OFF ROUTE 10

CITY OF PROVIDENCE  
COUNTY OF PROVIDENCE

R.I. CONTRACT NO. F.A. PROJECT NO.  
.15 MILES



LOCATION MAP  
SCALE - 1" = 1,000'

DESIGN	DESIGNATION
AADT	XX V.P.D.
AADT	XX V.P.D.
D	XX/XX
K	XX%
T	XX%
DDHV	XX V.P.H.
DHV	XX V.P.D.
DESIGN SPEED	35 M.P.H.

THIS INFORMATION SHALL BE PROVIDED ON ALL PROJECTS THAT CONTAIN WORK ON A DESIGNATED HURRICANE EVACUATION ROUTE, PER TAC 0087

**HURRICANE EVACUATION ROUTE**

This project includes work on a designated Hurricane Evacuation and Diversionary Route as follows:  
- On and Off ramps connecting Route 10 with Elmwood Avenue - Exit 1

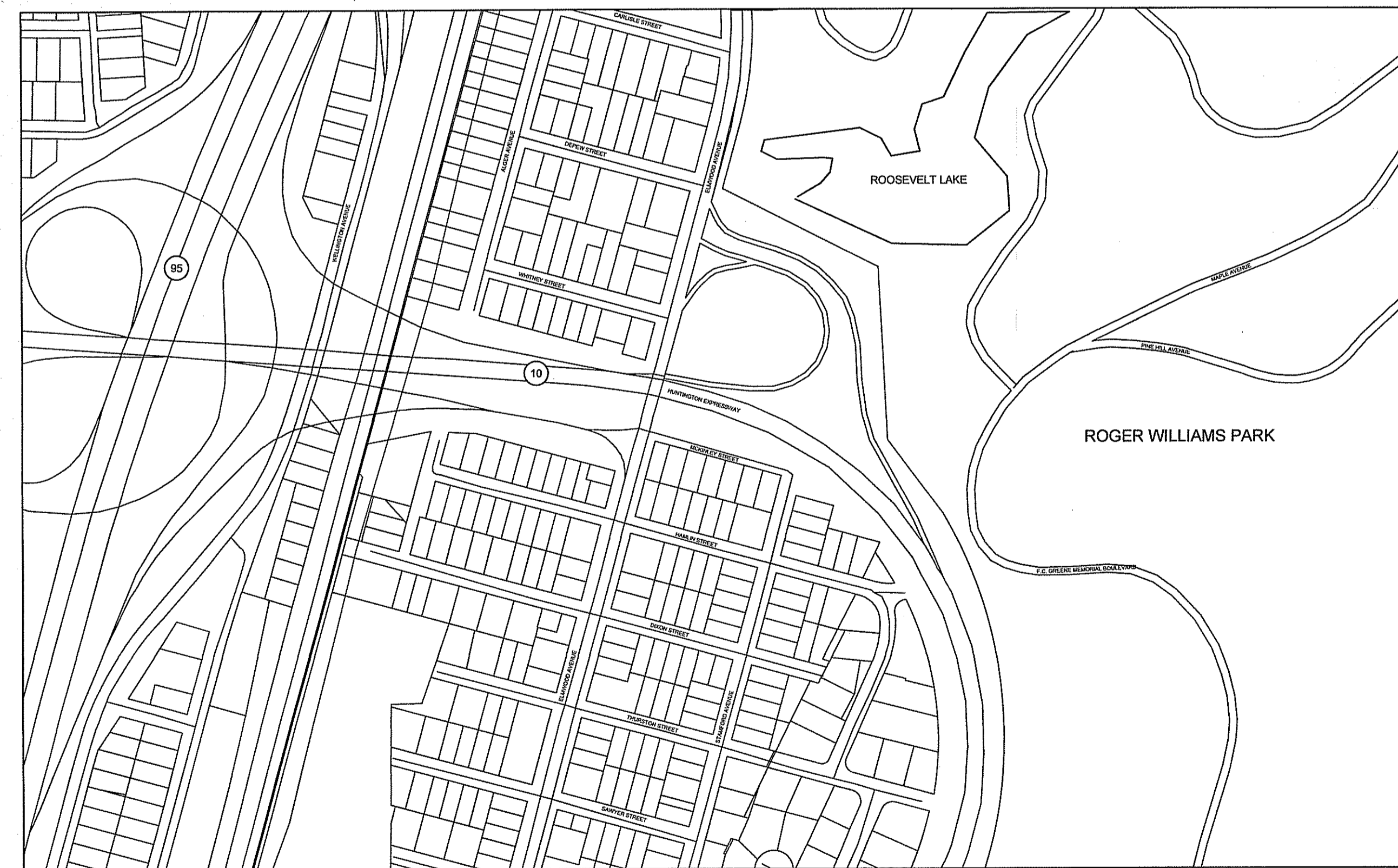

LAYOUT PLAN  
SCALE - 1" = 100'

**SCALES OF DRAWINGS**

Plans	1 inch = 10 feet
Plans	1 inch = 20 feet
Profiles	1 inch = 20 feet Horizontal
Profiles	1 inch = 4 feet Vertical
Cross Sections	1 inch = 4 feet Horizontal
Cross Sections	1 inch = 4 feet Vertical

BASE OF LEVELS  
NGVD 29

R.I. STANDARD SPECIFICATIONS AND STANDARD DETAILS  
SPECIFICATIONS TO GOVERN THIS PROJECT ARE THE R.I. STANDARD SPECIFICATIONS FOR ROAD AND BRIDGE CONSTRUCTION, 2004 EDITION, AND THE STATE AND FEDERAL SPECIAL PROVISIONS INCLUDED IN THE CONTRACT DOCUMENTS. STANDARD DETAILS FOR THIS PROJECT ARE R.I. STANDARD DETAILS, 1998 EDITION, WITH ALL REVISIONS.

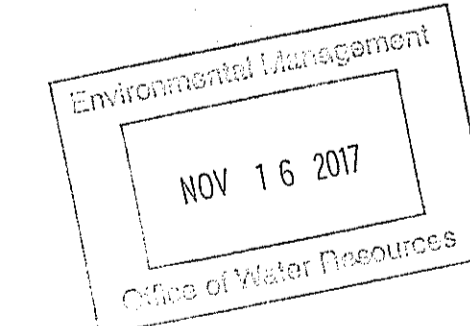
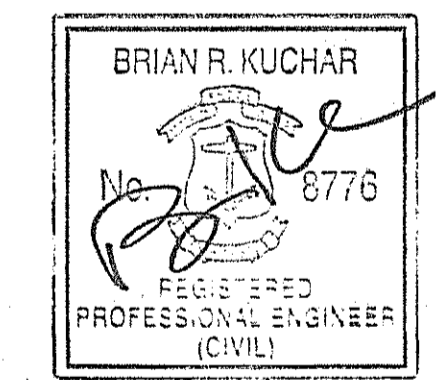

75% DESIGN

DEPARTMENT OF ENVIRONMENTAL MANAGEMENT  
OFFICE OF WATER RESOURCES  
FRESHWATER WETLANDS SECTION  
APPROVED WITH COMMENTS  
AS SPECIFIED IN THE LETTER OF APPROVAL  
DATED DEC 19 2017 FILE # 17-0275  
NO CHANGES ALLOWED WITHOUT APPROVAL  
APPROVED PLANS MUST BE AT THE OFFICE OF THE ENGINEER

*Charles A. Harte*

Horsley Witten Group, Inc.  
Sustainable Environmental Solutions  
www.horsleywitten.com  
90 Route 6A  
Sandwich, MA 02563  
508-833-6600 voice  
508-833-3150 fax

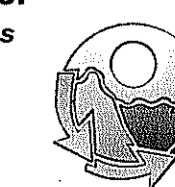

Contract Number \_\_\_\_\_  
Number of Sheet 1  
Total Sheets 11

R.I. DEPARTMENT OF TRANSPORTATION	
APPROVED	
ADMINISTRATOR OFFICE OF STORMWATER MANAGEMENT	DATE
APPROVED	
CHIEF ENGINEER	DATE
APPROVED	
DIRECTOR	DATE
DEPARTMENT OF TRANSPORTATION FEDERAL HIGHWAY ADMINISTRATION	
APPROVED	
DIVISION ADMINISTRATOR	DATE

EXISTING	NEW	EXISTING	NEW	EXISTING	NEW	EXISTING	NEW	EXISTING	NEW
EDGE OF PAVEMENT	EDGE OF PAVEMENT	(1.1.0)	UNDERDRAIN	(7.4.2)	GRANITE TRANSITION CURB (VERTICAL FACE TO SLOPE FACE)	(AB)	ADJUST CATCH BASIN TO GRADE	(NFB)	NEW FIRE HYDRANT WITH GATE VALVE
BERM	BERM	(1.3.0)	CONCRETE CONNECTING COLLAR	(7.5.0)	BITUMINOUS CONCRETE LIP CURB	(ABM)	ADJUST CATCH BASIN TO MANHOLE	(NIC)	NOT IN THIS CONSTRUCTION CONTRACT
CURB	CURB	(2.1.0)	CONCRETE HEADWALLS FOR PIPE CULVERTS	(7.5.1A)	BITUMINOUS BERM (CONSTRUCTION METHOD A)	(AC)	ADJUST CURB STOP TO GRADE	(NWB)	FURNISH AND INSTALL NEW WATER GATE VALVE BOX
GUARDRAIL	GUARDRAIL	(2.2.0)	STANDARD HEADWALLS FOR MULTIPLE 3'-6" TO 7'-0" PIPE CULVERTS	(7.5.1B)	BITUMINOUS BERM (CONSTRUCTION METHOD B)	(AD)	ADJUST DRAINAGE MANHOLE TO GRADE	(NWWB)	FURNISH AND INSTALL NEW WATER GATE VALVE AND BOX
MAILBOX	MAILBOX	(2.3.0) (DIA.)	PRECAST CONCRETE FLARED END SECTION	(7.6.0)	CURB SETTING DETAIL	(AE)	ADJUST ELECTRIC MANHOLE TO GRADE	(NWSB)	FURNISH AND INSTALL NEW WATER CURB STOP BOX
UTILITY POLE	UTILITY POLE	(3.2.0)	BRICK/SOLID BLOCK 4'-0" ROUND MANHOLE	(8.2.0)	BITUMINOUS CONCRETE DITCH	(AFC)	ADJUST FRAME AND COVER TO GRADE	(NWSB)	FURNISH AND INSTALL NEW WATER CURB STOP AND BOX
POLE GUY	POLE GUY	(3.2.1) (DIA.)	BRICK/SOLID BLOCK 5'-0" OR 6'-0" ROUND MANHOLE	(8.3.0)	RIP-RAP DITCH	(AFG)	ADJUST FRAME AND GRATE TO GRADE	(PCD)	PERMANENT CHECK DAM
LUMINAIRE	LUMINAIRE	(3.3.0)	BRICK/SOLID BLOCK TYPE "D" SQUARE CATCH BASIN	(8.4.0)	PAVED WATERWAY	(AG)	ADJUST GAS GATE BOX TO GRADE	(PS)	4" PLANTABLE SOIL AND SEED
SIGN	SIGN	(3.3.2)	BRICK/SOLID BLOCK TYPE "F" SQUARE CATCH BASIN	(9.1.0)	BALED HAY EROSION CHECK	(AHH)	ADJUST HANDHOLE TO GRADE	(RCB)	RECONSTRUCT TYPE "D" CATCH BASIN, TO CATCH BASIN WITH GUTTER INLET
SUBDRAIN	SUBDRAIN	(3.3.3)	SOLID BLOCK FLUSH SQUARE CATCH BASIN	(9.2.0)	SILT FENCE DETAIL	(AS)	ADJUST SANITARY SEWER MANHOLE TO GRADE	(RCM)	R.I.D.O.T. COMMUNICATIONS MANHOLE
STORMDRAIN	STORMDRAIN	(3.4.0)	BRICK/SOLID BLOCK TYPE "D" ROUND CATCH BASIN	(9.3.0)	BALED HAY DITCH EROSION CHECK AND SILT FENCE COMBINED	(AT)	ADJUST TELEPHONE MANHOLE TO GRADE	(RHH)	REMOVE, HANDLE, HAUL, TRIM, RESET CURB EDGING, STRAIGHT, CIRCULAR (ALL TYPES)
SANITARY SEWER	SANITARY SEWER	(3.4.1)	BRICK/SOLID BLOCK ROUND CATCH BASIN WITH GUTTER INLET	(9.4.0)	BALED HAY DITCH AND SWALE EROSION CHECK	(AW)	ADJUST WATER GATE BOX TO GRADE	(RLP)	RELOCATE LAMP POST
WATER MAIN	WATER MAIN	(3.4.2)	BRICK/SOLID BLOCK TYPE "F" ROUND CATCH BASIN	(9.5.0)	LOG AND HAY CHECK DAM	(BCD)	ADJUST WATER GATE BOX TO GRADE	(RMB)	RELOCATE MAILBOX (BY OTHERS)
GAS MAIN	GAS MAIN	(3.4.3)	BRICK/SOLID BLOCK TYPE "R" CATCH BASIN	(9.7.0)	DEWATERING BASIN	(BPS)	BUILD NEW STRUCTURE OVER EXISTING PIPE	(RPM)	REMOVE PAVEMENT MARKINGS
TELEPHONE DUCT	TELEPHONE DUCT	(3.4.4)	SOLID BLOCK FLUSH ROUND CATCH BASIN	(9.8.0)	BALED HAY CATCH BASIN INLET PROTECTION	(CCB)	CLEAN CATCH BASIN	(RRP)	RIP-RAP PAD (SEE DETAIL)
ELECTRIC DUCT	ELECTRIC DUCT	(3.4.5) (DIA.)	BRICK/SOLID BLOCK 5'-0" OR 6'-0" ROUND CATCH BASIN	(9.9.0)	CONSTRUCTION ACCESS	(CCP)	CUT AND CAP PIPE WITH RESTRAINT (ALL SIZES)	(RRS)	REMOVE AND RELOCATE SIGN
PLUG AND CAP PIPE	PLUG AND CAP PIPE	(3.5.0)	SOLID BLOCK SHALLOW TYPE "F" SQUARE CATCH BASIN	(10.1.0)	WET STONE MASONRY RETAINING WALL	(CFP)	CLEAN AND FLUSH PIPE	(RUP)	RELOCATE UTILITY POLE (BY OTHERS)
ABANDONED UTILITY	ABANDONED UTILITY	(3.5.1) (SIZE)	SOLID BLOCK SHALLOW 5'-0" OR 6'-0" SQUARE CATCH BASIN	(10.2.0)	RUBBLE MASONRY WALL	(CG)	CLEARING AND GRUBBING	(SB)	STONE BAFFLE
FLARED END SECTION	FLARED END SECTION	(3.6.0)	BRICK/SOLID BLOCK DROP INLET	(10.3.0)	CONCRETE RETAINING WALL	(CMH)	CLEAN MANHOLE	(SBAE)	STEEL BEAM BRIDGE CONNECTION APPROACH END (W/D NESTED RAIL)
HEADWALL	HEADWALL	(3.7.0) (DIA.)	BRICK/SOLID BLOCK ROUND MANHOLE OR CATCH BASIN GREATER THAN 12'-0"	(10.4.0)	STONE MASONRY STEPS	(CP) (DEPTH)	COLD PLANE	(SBTE)	STEEL BEAM BRIDGE CONNECTION TRAILING END (W/NESTED RAIL)
WATER OR GAS GATE	WATER OR GAS GATE	(4.2.0)	PRECAST 4'-0" ROUND MANHOLE	(14.1.0)	CONCRETE HIGHWAY BOUND	(CPP)	CUT AND PLUG PIPE (ALL TYPES, ALL SIZES)	(SD-)	STRUCTURAL DISPOSITION - SEE CS PAGES OF SPECIFICATION
CATCH BASIN	CATCH BASIN	(4.2.1)	PRECAST 5'-0" ROUND MANHOLE	(15.1.0)	POST AND MOUNTINGS FOR RURAL MAILBOX	(DB)	REMOVE AND DISPOSE BITUMINOUS CURB	(SF)	REMOVE AND STOCKPILE FENCE
MANHOLE	MANHOLE	(4.2.2)	PRECAST 6'-0" ROUND MANHOLE	(15.2.0) (NO.)	POST AND MULTIPLE MOUNTINGS FOR RURAL MAILBOXES	(DC)	REMOVE AND DISPOSE CONCRETE CURB	(SGA)	SPECIAL GRADED AGGREGATE
HYDRANT	HYDRANT	(4.3.0) (SIZE)	PRECAST 4'-0" OR 6'-0" SQUARE MANHOLE OR CATCH BASIN	(18.2.0)	PRECAST TYPE "A" HANDHOLE	(DCB)	REMOVE AND DISPOSE CATCH BASIN	(SGC)	REMOVE AND STOCKPILE GRANITE CURB
BASELINE OR CENTERLINE	BASELINE OR CENTERLINE	(4.4.0) (DIA.)	PRECAST 4'-0", 5'-0", OR 6'-0" ROUND CATCH BASIN	(18.2.2)	HEAVY DUTY TYPE "H" HANDHOLE	(DDI)	REMOVE AND DISPOSE DROP INLET	(SGR)	REMOVE AND STOCKPILE GUARDRAIL
STATE HIGHWAY LINE	STATE HIGHWAY LINE	(4.5.0)	PRECAST CONCRETE DROP INLET	(18.3.0)	ALUMINUM LIGHTING STANDARDS	(DF)	REMOVE AND DISPOSE FENCE	(SH)	REMOVE AND STOCKPILE HYDRANT
STATE FREEWAY LINE	STATE FREEWAY LINE	(4.5.1)	PRECAST CONCRETE DROP INLET LATERAL OUTLET	(20.2.0)	BI-DIRECTIONAL CONTROL DEVICE	(DFC)	REMOVE AND DISPOSE FRAME AND COVER	(SS)	REMOVE AND STOCKPILE SIGN
PERMANENT EASEMENT LINE	PERMANENT EASEMENT LINE	(4.5.2)	PRECAST CONCRETE DROP INLET LONGITUDINAL OUTLET	(24.6.1)	STREET SIGN MOUNTING DETAIL	(DFE)	REMOVE AND DISPOSE FLARED END SECTION	(STS)	REMOVE AND STOCKPILE TRAFFIC SIGNAL SYSTEM
TEMPORARY EASEMENT LINE	TEMPORARY EASEMENT LINE	(4.5.3)	CATCH BASIN AND MANHOLE STEP	(26.2.0)	POLYETHYLENE DRUM WITH MARKINGS	(DFG)	REMOVE AND DISPOSE FRAME AND GRATE	(TB)	CONCRETE THRUST BLOCK
PROPERTY LINE	PROPERTY LINE	(4.5.4)	CONCRETE COLLARS	(26.3.0)	PVC PLASTIC PIPE TYPE III BARRICADE	(DFH)	REMOVE AND DISPOSE FIRE HYDRANT	(TEP)	TIE EXISTING PIPE INTO NEW STRUCTURE
CITY OR TOWN LINE	CITY OR TOWN LINE	(4.5.5)	LIGHT-DUTY SQUARE FRAME AND ROUND COVER	(31.1.0)	CHAIN LINK FENCE 3'-0" TO 4'-0"	(DFP)	REMOVE AND DISPOSE FLEXIBLE PAVEMENT	(TNP)	TIE NEW PIPE INTO EXISTING STRUCTURE
PAVED WATERWAY	PAVED WATERWAY	(6.1.0)	HEAVY DUTY SQUARE FRAME AND ROUND COVER	(31.2.0)	CHAIN LINK FENCE 5'-0" TO 6'-0"	(DG)	REMOVE AND DISPOSE GUARDRAIL	(TBT)	THREE BEAM TRANSITION
CONTOUR LINE	CONTOUR LINE	(6.1.1)	LIGHT-DUTY ROUND FRAME AND COVER	(31.2.1)	CHAIN LINK FENCE 5'-0" TO 6'-0" INTERMEDIATE POST	(DH)	REMOVE AND DISPOSE HEADWALL	(TBBC)	THREE BEAM BRIDGE CONNECTION
OPEN DITCH	OPEN DITCH	(6.2.0)	HEAVY-DUTY ROUND FRAME AND COVER	(31.3.0)	WOVEN WIRE RIGHT-OF-WAY FENCE (STEEL POST)	(DHB)	REMOVE AND DISPOSE HIGHWAY BOUND	(TT)	TREE TRIMMING
R.I. HIGHWAY BOUND	R.I. HIGHWAY BOUND	(6.2.1)	SQUARE FRAME AND GRATE	(34.1.0)	TYPICAL GUARDRAIL INSTALLATION	(DHH)	REMOVE AND DISPOSE HANDHOLE	(WCM)	4" WOOD CHIP MULCH
STONE BOUND	STONE BOUND	(6.3.0)	SQUARE FRAME AND GRATE	(34.2.0)	STEEL BEAM GUARDRAIL	(DL)	REMOVE AND DISPOSE LIGHT AND FOUNDATION	(4DY)	4" EPOXY RESIN PAVEMENT MARKINGS - DOUBLE YELLOW
RETAINING WALL	RETAINING WALL	(6.3.1)	SQUARE FRAME AND GRATE (BICYCLE SAFE)	(34.2.1)	STEEL BEAM GUARDRAIL DETAILS	(DMB)	REMOVE AND DISPOSE MEDIAN BARRIER	(6W)	6" EPOXY RESIN PAVEMENT MARKINGS - WHITE
FIELD STONE WALL	FIELD STONE WALL	(6.3.2)	HIGH CAPACITY FRAME AND GRATE	(34.2.2)	STEEL BEAM GUARDRAIL DOUBLE FACED ASSEMBLY	(DMH)	REMOVE AND DISPOSE MANHOLE	(12W)	12" EPOXY RESIN PAVEMENT MARKINGS - WHITE
BORINGS	BORINGS	(6.3.3)	HIGH CAPACITY FRAME AND GRATE (BICYCLE SAFE)	(34.2.3)	STEEL BEAM GUARDRAIL FIXTURES	(DMM)	REMOVE AND DISPOSE MEDIAN MARKER	(6WT)	6" PREFORMED PATTERNED MARKING (HIGH PERFORMANCE TAPE)
FENCE	FENCE	(6.3.4)	ROUND FRAME AND GRATE	(34.2.5)	STEEL BEAM GUARDRAIL REFLECTORIZED TRIANGULAR DELINEATOR	(DOW)	REMOVE AND DISPOSE OBSERVATION WELL	(4Y)	4" EPOXY RESIN PAVEMENT MARKINGS - YELLOW
WOOD OR BRUSH LINE	WOOD OR BRUSH LINE	(6.4.0)	PRECAST CONCRETE CURB (STRAIGHT)	(34.3.1)	GUARDRAIL END SECTION	(DP)	REMOVE AND DISPOSE PIPE	(6Y)	6" EPOXY RESIN PAVEMENT MARKINGS - YELLOW
TREES	TREES	(7.1.0S)	PRECAST CONCRETE CURB (CIRCULAR)	(34.3.2)	TERMINAL END SECTION (SINGLE FACE)	(DPB)	REMOVE AND DISPOSE PAVEMENT AND RIGID BASE	(P.G.L.)	PROFILE GRADE LINE
RIVER OR STREAM	RIVER OR STREAM	(7.1.1)	3'-0" PRECAST CONCRETE TRANSITION CURB	(34.3.3)	ANCHORAGE DETAILS APPROACH END SECTION	(DRB)	REMOVE AND DISPOSE RIGID BASE		
WETLAND AREA	WETLAND AREA	(7.1.2)	6'-0" PRECAST CONCRETE TRANSITION CURB	(34.3.4)	ANCHORAGE DETAILS TRAILING END SECTION	(DS)	REMOVE AND DISPOSE SIGN		
BUILDING	BUILDING	(7.1.4)	PRECAST 2'-0" RADIUS CORNER	(34.4.0)	STEEL BACKED TIMBER GUARDRAIL	(DSS)	REMOVE AND DISPOSE TRAFFIC SIGNAL SYSTEM		
FOUNDATION	FOUNDATION	(7.1.5)	PRECAST CONCRETE INLET STONE (FOR SQUARE CATCH BASIN)	(34.4.1)	STEEL BACKED TIMBER GUARDRAIL TERMINAL SECTION-TYPE 1	(DSW)	REMOVE AND DISPOSE SIDEWALK		
BUILDING TO BE REMOVED	BUILDING TO BE REMOVED	(7.1.6)	PRECAST CONCRETE INLET STONE (FOR ROUND CATCH BASIN)	(40.1.0)	DOUBLE-FACED PRECAST MEDIAN BARRIER	(DTD)	REMOVE AND DISPOSE TELEPHONE DUCT BANKS		
RAILROAD TRACKS	RAILROAD TRACKS	(7.1.7)	PRECAST CONCRETE APRON STONE (FOR SQUARE CATCH BASIN)	(40.2.0)	SINGLE-FACED PRECAST MEDIAN BARRIER	(DUP)	REMOVE AND DISPOSE UTILITY POLE		
CUT AND MATCH	CUT AND MATCH	(7.1.8)	PRECAST CONCRETE APRON STONE (FOR ROUND CATCH BASIN)	(40.2.1)	SINGLE-FACED PRECAST MEDIAN BARRIER	(DWW)	REMOVE AND DISPOSE PAVED WATERWAY		
RIP-RAP	RIP-RAP	(7.2.0S)	PRECAST CONCRETE SLOPED FACE CURB (STRAIGHT)	(40.3.0)	PRECAST MEDIAN BARRIER TRANSITION UNIT	(FF)	REMOVE AND DISPOSE FILTER FABRIC RIPRAP FLARED END UNDERLAYMENT		
CUT SLOPE	CUT SLOPE	(7.2.0C)	PRECAST CONCRETE SLOPED FACE CURB (CIRCULAR)	(40.5.0)	PRECAST MEDIAN BARRIER FOR TEMPORARY TRAFFIC CONTROL	(GET)	FLARED GUARDRAIL END TREATMENT		
FILL SLOPE	FILL SLOPE	(7.2.1)	PRECAST CONCRETE SLOPED FACE TRANSITION CURB	(43.1.0)	CEMENT CONCRETE SIDEWALK	(IA)	IMPACT ATTENUATOR		
ROCK CUT	ROCK CUT	(7.2.2)	PRECAST CONCRETE TRANSITION CURB (VERTICAL FACE TO SLOPED FACE)	(43.2.0)	BITUMINOUS CONCRETE SIDEWALK	(IDL)	IMPERVIOUS DITCH LINER		
SPOT GRADE	SPOT GRADE	(7.3.0S)	GRANITE CURB (STRAIGHT)	(43.3.0)	WHEELCHAIR RAMP	(LOR)	LIMIT OF DISTURBANCE		
AREA GRADED TO DRAIN	AREA GRADED TO DRAIN	(7.3.0C)	GRANITE CURB (CIRCULAR)	(43.3.1)	WHEELCHAIR RAMP FOR LIMITED RIGHT-OF-WAY AREAS	(LS)	LIMIT OF REGRADING		
BALED HAY RI STD. 9.1.0	BALED HAY RI STD. 9.1.0	(7.3.1)	3'-0" GRANITE TRANSITION CURB	(43.4.0)	DRIVEWAY DEVELOPMENT FOR 3'-0" TRANSITION CURB		LIMIT OF CLEARING		
BALED HAY & SILT FENCE RI STD. 9.3.0	BALED HAY & SILT FENCE RI STD. 9.3.0	(7.3.2)	6'-0" GRANITE TRANSITION CURB	(43.4.1)	DRIVEWAY DEVELOPMENT FOR 6'-0" TRANSITION CURB				
EDGE OF WETLAND	EDGE OF WETLAND	(7.3.3)	GRANITE WHEELCHAIR RAMP TRANSITION CURB	(43.5.0)	CEMENT CONCRETE DRIVEWAYS				
WETLAND PERIMETER	WETLAND PERIMETER	(7.3.4)	GRANITE 2'-0" RADIUS CORNER	(48.1.0)	DETECTABLE WARNING SYSTEM				
AREA SUBJECT TO STORM FLOW	AREA SUBJECT TO STORM FLOW	(7.3.5)	GRANITE INLET STONE (FOR SQUARE CATCH BASIN)	(51.1.0)	TREE PROTECTION DEVICE				
100-YEAR FLOOD PLAIN	100-YEAR FLOOD PLAIN	(7.3.6)	GRANITE INLET STONE (FOR ROUND CATCH BASIN)	(51.1.1)	DRIP LINE TREE PROTECTION DEVICE FOR EXISTING TREES				
LIMIT OF DISTURBANCE	LIMIT OF DISTURBANCE	(7.3.7)	GRANITE APRON STONE (FOR SQUARE CATCH BASIN)	(51.2.0)	SHRUB PROTECTION DEVICE				
LIMIT OF CLEARING	LIMIT OF CLEARING	(7.3.8)	GRANITE APRON STONE (FOR ROUND CATCH BASIN)	(51.3.0)	TREE WELL				
		(7.4.0)	GRANITE SLOPED FACE CURB	(51.4.0)	TREE WALL				
		(7.4.1)	GRANITE SLOPED FACE TRANSITION CURB						

DEPARTMENT OF ENVIRONMENTAL MANAGEMENT  
OFFICE OF WATER RESOURCES  
FRESHWATER WETLAND PROGRAM  
APPROVED WITH COMMENTS  
AS SPECIFIED IN THE LETTER OF APPROVAL  
DATED DEC 19 2017 FILE # 17-0375  
NO CHANGES ALLOWED WITHOUT PREVIOUS APPROVAL  
APPROVED PLANS MUST BE AT CONSULTING ENGINEER'S OFFICE

*Charles A. Herbert*

Environmental Management  
NOV 16 2017

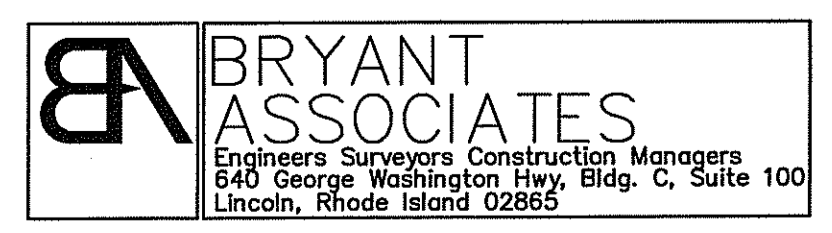

Horsley Witten Group, Inc.  
Sustainable Environmental Solutions  
www.horsleywitten.com  
90 Route 6A  
Sandwich, MA 02563  
508-833-6600 voice  
508-833-3150 fax



RHODE ISLAND  
DEPARTMENT OF TRANSPORTATION

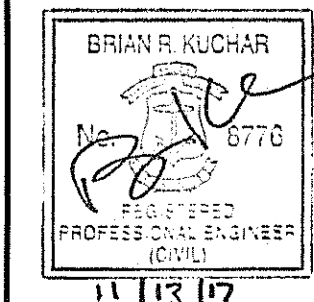

DESIGNED BY: GSG  
CHECKED BY: BRK  
DATE: 11/13/2017  
SHEET: 2  
OF: 11

SCALE: N/A					
REVISIONS		REVISIONS			
NO.	DATE	BY	NO.	DATE	BY

STORMWATER IRETROFITS  
ROGER WILLIAMS PARK-SITES 7A & 7B  
CONTRACT: 00 VOLUME:1  
PROVIDENCE RHODE ISLAND  
LEGEND & CALLOUTS

FED. ROAD DIV. NO.	STATE	FEDERAL AID PROJECT NO.	FISCAL YEAR	SHEET NO.	TOTAL SHEETS
00	RI	----	2018	3	11

**GENERAL NOTES:**

- ANY DAMAGE TO EXISTING PAVEMENT, BRIDGES, CONDUIT, SIDEWALK, FENCES, ETC., CAUSED BY THE CONTRACTOR SHALL BE REPAIRED BY THE CONTRACTOR AT NO ADDITIONAL COST TO THE STATE.
- THE CONTRACTOR SHALL PLACE ALL EQUIPMENT AND MATERIAL AS FAR AWAY AS POSSIBLE FROM THE EDGE OF THE TRAVEL LANE SO AS NOT TO CAUSE A SAFETY HAZARD, IN ACCORDANCE WITH SECTION 106.06 OF THE R.I.D.O.T. STANDARD SPECIFICATION, LATEST EDITION.
- IT IS THE CONTRACTOR'S RESPONSIBILITY TO ENSURE THAT THE EXISTING CONDITIONS ARE NOT OBLITERATED BEFORE CONTROL POINTS ARE LOCATED AND CONSTRUCTION LAYOUT IS ESTABLISHED. THE CONSTRUCTION LAYOUT SHALL BE PROVIDED IN SUFFICIENT DETAIL, THEREBY ENABLING HIM TO CONSTRUCT THE PROJECT IN CONFORMITY WITH THE PLANS AND SPECIFICATIONS. SURVEY WILL BE PROVIDED BY THE CONTRACTOR. THE RESIDENT ENGINEER WILL NOT AUTHORIZE CONSTRUCTION ACTIVITIES TO BEGIN UNTIL HE IS SATISFIED THAT ALL GROUND CONTROL HAS BEEN ESTABLISHED, TIED DOWN, AND DULY RECORDED IN STANDARD FIELD BOOKS.
- ALL R.I. STD. 9.9.0 CONSTRUCTION ACCESS ROADS SHALL BE CONSTRUCTED PRIOR TO ANY ROADWAY ACCEPTING CONSTRUCTION TRAFFIC.
- THE FREQUENCY AND APPLICATION RATES FOR THE DUST CONTROL ITEMS WILL BE AS DIRECTED BY THE ENGINEER.
- ALL SIDEWALK AND DRIVEWAYS DESIGNATED FOR REPLACEMENT SHALL BE CUT AND MATED AT LOCATIONS SHOWN ON THE PLANS OR AS DIRECTED BY THE ENGINEER.
- ASPHALT EMULSION TACK COAT SHALL BE PLACED PRIOR TO PAVEMENT PLACEMENT ON THE CONCRETE BASE OR COLD PLANED PAVEMENT, AND ON ANY NEW COURSE WHICH HAS BEEN OPEN TO TRAFFIC, OR ANY NEW COURSE WHICH HAS BEEN EXPOSED FOR MORE THAN 3 DAYS, AND/OR AS DIRECTED BY THE ENGINEER. IT SHALL ALSO BE APPLIED TO VERTICAL PAVEMENT FACES BETWEEN ADJOINING PAVEMENT SECTIONS. ALL APPLICATIONS ON BOTH HORIZONTAL AND VERTICAL SURFACES SHALL BE PAID FOR UNDER THE CONTRACT UNIT BID PRICE FOR CODE 403.0300 "ASPHALT EMULSION TACK COAT."
- THE LIMITS OF CLEARING AND SURFACE DISTURBANCE MUST BE STRICTLY ADHERED TO IN ALL AREAS. IN ADDITION TO THOSE AREAS SPECIFICALLY DESIGNATED ON THE PLANS, THE CONTRACTOR WILL BE RESPONSIBLE FOR PROVIDING AND PLACING, AT HIS OWN EXPENSE, PLANTABLE SOIL AND SEED IN AREAS WHICH ARE OUTSIDE OF THE PROJECT'S AREAS OF DISTURBANCE AND WHICH ARE IMPACTED BY CONSTRUCTION OPERATIONS INCLUDING THOSE AREAS WHERE VEHICLES, EQUIPMENT AND MATERIALS ARE STORED WITH THE PERMISSION OF THE ENGINEER.
- UNDER NO CIRCUMSTANCE WILL THE CONTRACTOR BE ALLOWED TO STOCKPILE REMOVED PAVEMENT MATERIALS WITHIN THE PROJECT LIMITS.
- CLEANING AND SWEEPING OF PAVEMENT WILL INCLUDE REMOVAL OF ALL PAVEMENT DEBRIS PRIOR TO THE PLACEMENT OF EACH BITUMINOUS PAVEMENT LIFT. ALL CLEANING AND SWEEPING SHALL BE DONE TO THE SATISFACTION OF THE ENGINEER.
- PRIOR TO INSTALLATION, ALL SIGNS, MOUNTINGS AND LOCATIONS SHALL BE APPROVED OR MODIFIED BY THE ENGINEER.
- THE COORDINATE SYSTEM IS THE R.I. STANDARD GRID SYSTEM, NAD 83. THE VERTICAL CONTROL IS NGVD 29.
- PAVEMENT OPERATIONS FOR CURBED SECTIONS: IN AREAS WHERE CURBING IS SET TO FINISH LINE AND GRADE, THE CONTRACTOR WILL NOT BE REQUIRED TO UTILIZE THE SENSOR AND SKY-TYPE DEVICE FOR AUTOMATIC GRADE CONTROL, BUT WILL BE ALLOWED TO MANUALLY ADJUST THE BITUMINOUS PAVER FOR CONTROLLING GRADE.
- THE CONTRACTOR SHALL BE RESPONSIBLE FOR MAINTAINING ALL ROADWAYS FREE OF DEBRIS RESULTING FROM THEIR CONSTRUCTION OPERATIONS. ALL DEBRIS SHALL BE REMOVED TO THE SATISFACTION OF THE ENGINEER AT NO ADDITIONAL COST TO THE STATE.
- NO FUEL STORAGE, VEHICLE REFUELING, OR EQUIPMENT STORAGE SHALL TAKE PLACE IN DESIGNATED WETLANDS, NOR WITHIN 100' OF ANY WATER BODY. THIS REQUIREMENT SHALL NOT SUPERSEDE ANY FEDERAL, STATE OR LOCAL LAW, ORDINANCE, RULE OR REGULATION THAT APPLIES TO THE SAME, UNLESS THIS REQUIREMENT IS MORE STRINGENT THAN SAID LAW, ORDINANCE, RULE OR REGULATION.
- THE CONTRACTOR SHALL BE RESPONSIBLE TO ENSURE THAT AT THE END OF FINAL PAVING OPERATIONS, FLOW TO EXISTING DRAINAGE STRUCTURES HAS BEEN REESTABLISHED AND THAT NO ISOLATED DEPRESSIONS REMAIN. THERE SHALL BE NO SEPARATE PAYMENT FOR THIS PROVISION; IT SHALL BE CONSIDERED INCIDENTAL TO PAVING AND COLD PLANING OPERATIONS.
- ALL EMBANKMENTS SHALL BE PLACED IN HORIZONTAL LAYERS NOT EXCEEDING 12" (AFTER COMPACTION) AND SHALL BE COMPACTED AS SPECIFIED BEFORE THE NEXT LAYER IS PLACED. ALSO, EMBANKMENT CONSTRUCTION SHALL CONFORM TO SECTION 202.03.2 OF THE R.I.D.O.T. STANDARD SPECIFICATIONS, LATEST EDITION.
- IF THIS PROJECT IS ON A HURRICANE EVACUATION AND DIVERSIONARY ROUTE, AS DESIGNATED ON THE COVERSHEET, THE CONTRACTOR IS ADVISED THAT UPON 12 (TWELVE) HOURS NOTICE THE ROADWAY SHALL BE OPEN TO EVACUEES AND EMERGENCY PERSONNEL. ANY EXTRA WORK NECESSARY TO COMPLY WITH THIS REQUIREMENT WILL BE REIMBURSED UNDER FORCE ACCOUNT PROCEDURES.
- THE CONTRACTOR SHALL READ, BECOME FAMILIAR WITH, AND ADHERE TO ALL OF THE PROVISIONS, CONDITIONS, AND STIPULATIONS STATED IN THE ENVIRONMENTAL APPROVALS ISSUED FOR THE PROJECT FROM THE DEPARTMENT OF ENVIRONMENTAL MANAGEMENT (RIDEM), AND/OR THE ARMY CORPS OF ENGINEERS (ACOE), AND/OR THE COASTAL RESOURCES MANAGEMENT COUNCIL (CRMC), COPIES OF EACH OF THESE PERMITS ARE INCLUDED IN THE CS PAGES OF THE CONTRACT DOCUMENTS. ALL COSTS ASSOCIATED WITH THESE CONDITIONS SHALL BE CONSIDERED INCIDENTAL TO THE CONSTRUCTION AND INCLUDED WITH THE COST FOR THE ASSOCIATED BID ITEM(S).
- FOR ALL PROJECTS INVOLVING KNOWN SITE REMEDIATION ISSUES, THE CONTRACTOR SHALL READ, BECOME FAMILIAR WITH, AND ADHERE TO ALL OF THE CONSTRUCTION RELATED PROVISIONS, CONDITIONS, AND STIPULATIONS OF ANY REMEDIAL PLANS DEVELOPED FOR THE PROJECT. COPIES OF THESE DOCUMENTS ARE INCLUDED IN THE CS PAGES OF THE CONTRACT DOCUMENTS. ALL COSTS ASSOCIATED WITH COMPLIANCE WITH THESE DOCUMENTS SHALL BE CONSIDERED INCIDENTAL TO THE CONSTRUCTION AND INCLUDED WITH THE COST FOR THE ASSOCIATED BID ITEM(S).
- NO UNPROTECTED CONSTRUCTED FEATURE MAY PROJECT MORE THAN 4 INCHES ABOVE THE FINISHED GRADE OF A TRAVERSABLE SLOPE IN A CLEAR ZONE, e.g. HEADWALL, DRAINAGE INLET, ETC.
- THE REMAINING SECTION OR STUB OF A BREAKAWAY BASE MAY NOT PROJECT MORE THAN 4 INCHES ABOVE THE FINISHED GRADE OF A TRAVERSABLE SLOPE IN A CLEAR ZONE, e.g. SIGN POSTS, LIGHT POLES, FIRE HYDRANTS, ETC.

**DRAINAGE AND EROSION CONTROL NOTES:**

- FOR ALL PROJECTS WITH AT LEAST ONE(1) ACRE OF SOIL DISTURBANCE, R.I.D.O.T. IS REQUIRED TO DEVELOP AND ENFORCE A SITE SPECIFIC STORM WATER POLLUTION PREVENTION PLAN (SWPPP) IN ORDER TO REMAIN IN COMPLIANCE WITH THE RIPDES GENERAL PERMIT FOR STORMWATER DISCHARGES ASSOCIATED WITH CONSTRUCTION ACTIVITIES. THE CONTRACTOR SHALL READ, BECOME FAMILIAR WITH, AND ADHERE TO ALL OF THE PROVISIONS, CONDITIONS, AND STIPULATIONS OF THE GENERAL PERMIT AND THE SITE SPECIFIC SWPPP FOR THIS PROJECT. COPIES OF THESE DOCUMENTS ARE INCLUDED IN THE CS PAGES OF THE CONTRACT DOCUMENTS. ALL COSTS ASSOCIATED WITH ADHERENCE TO THE SWPPP SHALL BE CONSIDERED INCIDENTAL TO THE CONSTRUCTION AND INCLUDED WITH THE COST FOR THE ASSOCIATED BID ITEM(S).
- NO UNDISTURBED AREAS SHALL BE CLEARED OF EXISTING VEGETATION AFTER OCTOBER 15 OF ANY CALENDAR YEAR OR DURING ANY PERIOD OF FULL OR LIMITED WINTER SHUTDOWN. ALL DISTURBED SOILS EXPOSED PRIOR TO OCTOBER 15 OF ANY CALENDAR YEAR SHALL BE SEED OR PROTECTED BY THAT DATE. ANY SUCH AREAS THAT DO NOT HAVE ADEQUATE VEGETATIVE STABILIZATION, AS DETERMINED BY THE RESIDENT ENGINEER OR ENVIRONMENTAL INSPECTOR, BY NOVEMBER 15 OF ANY CALENDAR YEAR, MUST BE STABILIZED THROUGH THE USE OF EROSION CONTROL MATTING OR HAY MULCH, IN ACCORDANCE WITH SPECIFICATIONS CONTAINED WITHIN THE R.I. SOIL EROSION AND SEDIMENT CONTROL HANDBOOK. IF WORK CONTINUES WITHIN ANY OF THESE AREAS DURING THE PERIOD FROM OCTOBER 15 THROUGH APRIL 15, CARE MUST BE TAKEN TO ENSURE THAT ONLY THE AREA REQUIRED FOR THAT DAY'S WORK IS EXPOSED, AND ALL ERODIBLE SOIL MUST BE RESTABILIZED WITHIN 5 WORKING DAYS. ANY WORK TO CORRECT PROBLEMS RESULTING FROM FAILURE TO COMPLY WITH THIS PROVISION SHALL BE THE RESPONSIBILITY OF THE CONTRACTOR. THERE WILL BE NO SEPARATE PAYMENT FOR THIS PROVISION. IT SHALL BE CONSIDERED INCIDENTAL TO CONSTRUCTION OPERATIONS. STABILIZATION OF ONE FORM OR ANOTHER AS DESCRIBED ABOVE SHALL BE ACHIEVED WITHIN 2 WEEKS OF FINAL GRADING.
- STOCKPILES OF MATERIAL SHALL NOT BE LOCATED WITHIN REGULATED WETLANDS OR BUFFER ZONE AREAS. THEY SHALL HAVE SIDE SLOPES NO GREATER THAN 30% AND STOCKPILES OF ERODABLE MATERIAL SHALL ALSO BE SEED OR RINGED WITH R.I. STD. 9.1.0 TO STABILIZE.
- IF THE PLANS INCLUDE SPECIFIC AREAS FOR PLACEMENT OF CONSTRUCTION DEWATERING BASINS AND/OR EQUIPMENT AND MATERIALS STORAGE AND STOCKPILING, AND IF THE CONTRACTOR ELECTS TO UTILIZE ANY OTHER AREAS FOR THESE PURPOSES, THIS SHALL BE APPROVED BY THE ENGINEER ONLY AFTER OBTAINING ANY NECESSARY PERMITS AND/OR PERMIT MODIFICATIONS FROM THE APPROPRIATE REGULATORY AUTHORITY(IES). ANY PERMITTING REQUIREMENTS SHALL BE THE RESPONSIBILITY OF THE CONTRACTOR AND SHALL BE ACCOMPLISHED AT NO COST TO THE STATE. THE ENGINEER WILL COORDINATE SUBMISSION OF ANY REQUIRED PERMIT APPLICATION MATERIALS WITH THE R.I.D.O.T. OFFICE OF ENVIRONMENTAL PROGRAMS.
- JUTE MESH SHALL BE USED TO STABILIZE PLANTABLE SOIL AND/OR LOAM IN ALL DITCHES, ON ALL SLOPES ADJACENT TO WETLANDS AND WETLAND PERIMETERS, AND ON ALL SLOPES WITHIN WATER QUALITY BASINS. JUTE MESH IN DITCHES SHALL EXTEND TO AN ELEVATION 2 FEET ABOVE THE BOTTOM OF THE DITCH.
- SEEDING ON ALL SLOPES 3 TO 1 OR STEEPER SHALL CONSIST OF THE FOLLOWING APPLICATIONS UNLESS CHANGED IN THE CONTRACT.
  - SEEDING TYPE I.
  - ADHESIVE MULCH STABILIZER
- UNVEGETATED SLOPES SHALL NOT BE UNATTENDED OR EXPOSED FOR PERIODS IN EXCESS OF 2 WEEKS OR THROUGH THE INACTIVE WINTER SEASON.
- PRIOR TO DRAINAGE AND UTILITY CONSTRUCTION, THE CONTRACTOR IS RESPONSIBLE FOR VERIFYING THE LOCATION (HORIZONTAL AND VERTICAL) OF ALL EXISTING PIPES AND/OR STRUCTURES WHICH ARE TO BE CONNECTED. ANY VARIATION FOUND FROM THE PLANS MUST BE BROUGHT TO THE ENGINEER'S ATTENTION PRIOR TO DRAINAGE AND UTILITY CONSTRUCTION. WORK CAN COMMENCE ONLY UPON THE ENGINEER'S AUTHORIZATION.
- ALL DRAINAGE AND UTILITY STRUCTURES WITHIN THE PAVED ROADWAY SHALL BE ADJUSTED TO GRADE WITH THE SURROUNDING PAVEMENT PRIOR TO THE WINTER SHUTDOWN.
- DURING CONSTRUCTION, THE CONTRACTOR SHALL BE RESPONSIBLE FOR MAINTAINING DRAINAGE AND RUNOFF FLOW DURING STORMS AND PERIODS OF RAINFALL THROUGHOUT THE WORK AREA.
- CATCH BASIN RIM GRADES NOTED ON PLANS ARE DEPRESSED 0.1' LOWER THAN THE GUTTER GRADE. RIM ELEVATIONS SHOWN ARE FINAL GRADES. THE CONTRACTOR SHALL PLACE FRAMES AND GRATES 0.1' BELOW THE GRADE CONSTRUCTED IN THIS CONTRACT OR AS DIRECTED BY THE ENGINEER.
- PROVISIONS FOR CLEARING TO ACCESS OUTFALLS DURING THE CLEANING AND FLUSHING OF THE CLOSED DRAINAGE SYSTEM SHALL BE KEPT TO A MINIMUM.
  - ANY VEGETATIVE CLEARING SHALL BE LIMITED TO BRUSH AND TREES LESS THAN 3" DIAMETER.
  - NO HEAVY EQUIPMENT MAY ENCRONCH UPON VEGETATED PERIMETER OR RIVERBANK WETLANDS AS WELL AS BIOLOGICAL WETLANDS.
- THE CONTRACTOR SHALL INSTALL ALL EROSION CONTROL DEVICES FOR OUTLET PROTECTION PRIOR TO CLEANING AND FLUSHING STORM WATER DRAINAGE. EROSION CONTROL DEVICES SHALL REMAIN IN PLACE UNTIL ALL FLUSHED SEDIMENTS ARE REMOVED. AT ALL OUTFALL LOCATIONS WHERE PIPES ARE TO BE CLEANED AND FLUSHED, OUTLET PROTECTION (R.I. STD. 9.1.0 OR 9.3.0) SHALL BE INSTALLED TO TRAP SEDIMENTS. THESE SEDIMENTS SHALL THEN BE REMOVED AND DISPOSED OF LEGALLY BEFORE THE OUTLET PROTECTION DEVICES ARE REMOVED. IF OUTLET PROTECTION AT THE OUTFALL IS NOT FEASIBLE, THEN THE OUTLET PIPE OF THE LAST DRAINAGE STRUCTURE TO BE CLEANED SHALL BE PLUGGED TO CAPTURE ALL MATERIALS FLUSHED FROM PIPES. AFTER THE MATERIALS ARE REMOVED FROM THE DRAINAGE STRUCTURE, THE OUTLET SHALL BE UNPLUGGED TO RESUME NORMAL FUNCTIONING.
- INSTALL A SILT SACK OR APPROVED EQUIVALENT, AS SHOWN IN THE DETAILS IN EACH EXISTING CATCHBASIN RECEIVING RUNOFF FROM THE SITE. UPON THE INSTALLATION OF EACH CATCH BASIN, INSTALL A SILT SACK. INSPECT SILT SACKS, AFTER EACH SIGNIFICANT STORM EVENT AND REMOVE AND EMPTY AS NEEDED FOR THE DURATION OF THE CONSTRUCTION PERIOD.
- WHERE SILT SACK INLET PROTECTION ARE USED AT CATCH BASINS, THEY SHALL BE REMOVED AT THE END OF THE PROJECT OR AS DIRECTED BY THE ENGINEER IN ORDER TO PREVENT CLOGGING OF THE INLET.

**DRAINAGE AND EROSION CONTROL NOTES (CONTINUED):**

- DETENTION AND RETENTION BASINS MAY BE ROUGH GRADED AND STABILIZED WITH VEGETATION AND/OR OTHER EROSION CONTROL MEASURES AS REQUIRED BY THE ENGINEER PRIOR TO USE AS TEMPORARY SEDIMENTATION BASINS DURING PROJECT CONSTRUCTION. FINAL BASIN CONSTRUCTION SHALL NOT COMMENCE UNTIL ALL SOURCES OF SEDIMENT HAVE BEEN ELIMINATED, FINAL ROADSIDE VEGETATION IS ESTABLISHED AND USE OF TEMPORARY BASINS IS NO LONGER REQUIRED AS DIRECTED BY THE ENGINEER. ANY ISSUES RELATING TO EROSION AND/OR SEDIMENT TRANSPORT INTO WETLAND AREAS RESULTING FROM SUCH USE OF SEDIMENTATION BASINS DURING CONSTRUCTION SHALL BE THE RESPONSIBILITY OF THE CONTRACTOR. ANY CORRECTIVE ACTION REQUIRED TO RESOLVE SUCH ISSUES SHALL BE COMPLETED BY THE CONTRACTOR.
- THE TOE OF ANY FILL SLOPE IS TO REMAIN AT LEAST 1' INSIDE OF ALL EROSION CONTROLS. UNDER NO CIRCUMSTANCES SHALL THE CONTRACTOR COVER ANY PORTION OF THE EROSION CONTROL MEASURES WITH MATERIAL. ANY MATERIAL THAT IS PLACED ON ANY EROSION CONTROLS BY THE CONTRACTOR, OR ANY AGENT OF THE CONTRACTOR, SHALL BE IMMEDIATELY REMOVED BY THE CONTRACTOR, AND ANY NECESSARY REPAIRS TO THE EROSION CONTROLS ACCOMPLISHED.
- PRIOR TO COMMENCING CONSTRUCTION ACTIVITIES, EROSION AND SEDIMENTATION CONTROLS SHALL BE INSTALLED AT THOSE AREAS INDICATED ON THE PLANS. CLEARING MAY OCCUR PRIOR TO INSTALLATION OF SUCH CONTROLS, HOWEVER NO GRUBBING, GRADING, FILLING, OR OTHER SOIL DISTURBANCE SHALL OCCUR PRIOR TO INSTALLATION. THE LIMITS OF CLEARING AND SURFACE DISTURBANCE MUST BE STRICTLY ADHERED TO IN ALL AREAS.
- ALL HAY BALES, SILT FENCE OR TEMPORARY PROTECTION SHALL REMAIN IN PLACE UNTIL AN ACCEPTABLE STAND OF GRASS IS ESTABLISHED. IF NEEDED, TEMPORARY SEEDING CAN HELP TO MINIMIZE EROSION. TEMPORARY SEED WILL CONFORM TO R.I.D.O.T. STANDARD TEMPORARY SEED MIX.
- THE CONTRACTOR MUST REPAIR AND/OR RESEED ANY AREAS THAT DO NOT DEVELOP WITHIN THE PERIOD OF ONE YEAR AND HE SHALL DO SO AT NO ADDITIONAL EXPENSE TO THE STATE.
- THE NORMAL ACCEPTABLE SEASONAL SEEDING DATES ARE SPECIFIED IN SUBSECTION L.02.03 OF THE R.I.D.O.T. STANDARD SPECIFICATIONS, LATEST EDITION.
- ADDITIONAL EROSION CONTROLS, SHALL BE INSTALLED AS DIRECTED BY THE RESIDENT ENGINEER. THESE ADDITIONAL ITEMS WILL BE PAID AT THE UNIT PRICE FOR THAT BID ITEM.

**LANDSCAPE NOTES:**

- ALL PLANT MATERIAL MUST BE TAGGED AT THE NURSERY (A RECOGNIZED GROWER OF PLANT MATERIAL) IN ACCORDANCE WITH THE R.I.D.O.T. STANDARD SPECIFICATIONS, LATEST EDITION. ALL PLANT MATERIAL MUST BE NURSERY GROWN; NO PLANTATION GROWN PLANT MATERIAL WILL BE ACCEPTED.
- ALL PLANT SUBSTITUTIONS AND/OR CHANGES IN PLANT LOCATION MUST BE APPROVED IN ACCORDANCE WITH THE R.I.D.O.T. STANDARD SPECIFICATIONS, LATEST EDITION.
- ALL PLANT MATERIAL IS TO BE FIELD LOCATED BY A REPRESENTATIVE FROM THE R.I.D.O.T. LANDSCAPE ARCHITECTURE UNIT.
- A R.I.D.O.T. LANDSCAPE REPRESENTATIVE MUST BE ON SITE TO APPROVE ALL TRIMMING AND CLEARING NECESSARY TO COMPLETE THE WORK AS SHOWN ON THE PLANS.
- ANY TOPSOIL USED AS PLANTABLE SOIL SHALL HAVE A SANDY LOAM TEXTURE RELATIVELY FREE OF SUBSOIL MATERIAL, STONES, ROOTS, LUMPS OF SOIL, TREE LIMBS, TRASH OR CONSTRUCTION DEBRIS, AND SHALL CONFORM TO SECTION M.18 OF THE R.I.D.O.T. STANDARD SPECIFICATIONS, LATEST EDITION.
- ALL TREES AND SHRUBS SHALL BE MULCHED WITH PINE BARK MULCH IN ACCORDANCE WITH THE R.I.D.O.T. STANDARD SPECIFICATIONS, LATEST EDITION.
- ALL TREES AND/OR SHRUBS THAT ARE PLANTED AS A BED SHALL BE MULCHED AS A BED.
- PROVIDE A MINIMUM 6"-8" BRANCHING STANDARD ON ALL TREES INSTALLED ADJACENT TO SIDEWALKS AND/OR PEDESTRIAN ACCESS AREAS.

**UTILITY NOTES:**

- EXISTING UTILITIES HAVE BEEN SHOWN ON THE PLANS USING THE BEST AVAILABLE INFORMATION AND ARE APPROXIMATE. BUILDING SERVICE CONNECTIONS (ELECTRIC, GAS, TELEPHONE, WATER AND SANITARY) ARE NOT SHOWN. CONTRACTOR IS TO ASSUME SERVICES ARE PRESENT TO ALL BUILDINGS.
- THE CONTRACTOR SHALL VERIFY THE LOCATIONS OF ALL EXISTING DRAINAGE AND UTILITIES BOTH UNDERGROUND AND OVERHEAD BEFORE EXCAVATION BEGINS IN ACCORDANCE WITH CHAPTER 39-1.2 OF THE R.I. GENERAL LAWS ENTITLED "EXCAVATION NEAR UNDERGROUND UTILITY FACILITIES", WITH AMENDMENTS EFFECTIVE AS OF NOVEMBER 1, 2009 AND, WHEN NECESSARY, BY CONTACTING THE INDIVIDUAL UTILITY COMPANIES. EXCAVATION SHALL BE IN ACCORDANCE WITH ALL STATUTES, ORDINANCES, RULES AND REGULATIONS OF ANY APPLICABLE CITY, TOWN, STATE OR FEDERAL AGENCY. THE CONTRACTOR SHOULD UNDERSTAND THAT NOT ALL UTILITIES SUBSCRIBE TO THE DIG SAFE PROGRAM. IT IS THE CONTRACTOR'S RESPONSIBILITY TO NOTIFY ALL UTILITY COMPANIES AND ENSURE THAT ALL UTILITIES HAVE BEEN MARKED PRIOR TO COMMENCING THEIR WORK. ANY DAMAGE TO EXISTING UTILITIES MARKED IN THE FIELD, OR AS A RESULT OF FAILING TO CONTACT THE APPROPRIATE UTILITY COMPANY, SHALL BE REPAIRED OR REPLACED AT NO ADDITIONAL COST TO THE STATE.
- ALL EXISTING UTILITIES TO BE ABANDONED SHALL BE CAPPED.
- EXISTING WATER SERVICES SHALL BE RECONNECTED TO THE NEW WATER MAINS.
- UTILITY SERVICE CONNECTIONS SHALL BE MAINTAINED TO ALL EXISTING FACILITIES TO REMAIN.
- FIRE HYDRANTS SHALL NOT BE REMOVED FROM SERVICE WITHOUT WRITTEN AUTHORIZATION FROM THE FIRE DEPARTMENT OR THE WATER AUTHORITY.
- ALL NEW WATER LINES SHALL BE DISINFECTED TO THE SATISFACTION OF THE WATER AUTHORITY IN ACCORDANCE WITH THE SPECIFICATIONS.
- ALL UTILITY POLE RELATED WORK SHALL BE BY OTHERS.

**MAINTENANCE AND PROTECTION OF TRAFFIC NOTES:**

- ALL MAINTENANCE AND PROTECTION OF TRAFFIC CONTROL SETUPS, SIGNS, CHANNELIZING DEVICES, ETC., SHALL BE IN ACCORDANCE WITH THE MANUAL ON UNIFORM TRAFFIC CONTROL DEVICES, LATEST EDITION.
- ALL SIGN MOUNTINGS FOR TEMPORARY AND CONSTRUCTION SIGNS SHALL BE IN ACCORDANCE WITH THE R.I.D.O.T. STANDARD SPECIFICATIONS, LATEST EDITION.
- THE CONTRACTOR SHALL COVER ALL EXISTING AND/OR TEMPORARY SIGNS THAT ARE NOT RELEVANT TO THE TRAFFIC CONTROL REQUIRED DURING ANY PARTICULAR STAGE OF THE CONTRACT.
- ADVANCE FLAGPERSON SIGNS (W20-7A) SHALL BE USED IN ADVANCE OF ANY POINT AT WHICH A FLAGPERSON OR A POLICE OFFICER HAS BEEN STATIONED TO CONTROL TRAFFIC. WHEN NEEDED, AN APPROPRIATE DISTANCE MESSAGE MAY BE DISPLAYED ON A SUPPLEMENTAL PLATE (24"x18") BELOW THE FLAGPERSON SYMBOL SIGN. THE SIGN SHALL BE PROMPTLY REMOVED OR COVERED WHENEVER THE FLAGPERSON IS NOT AT THE STATION.
- POLICE OFFICERS (AND NOT FLAGPERSONS) SHALL BE UTILIZED WHEN WORK WILL IMPACT SIGNALIZED INTERSECTIONS AND LIMITED ACCESS HIGHWAYS.
- POLYETHYLENE DRUMS SHALL BE UTILIZED AS A CHANNELIZING DEVICE WHEN A TRAFFIC CONTROL SET-UP IS TO REMAIN BEYOND WORKING HOURS WHEN NO WORKERS ARE PRESENT. CONES SHALL BE UTILIZED WHEN A TRAFFIC CONTROL SET-UP IS TO REMAIN ONLY DURING WORKING HOURS AND IS SUBSEQUENTLY BROKEN DOWN AT THE END OF THE WORKDAY.
- ARROW PANELS SHALL BE SET IN THE FLASHING FOUR CORNERS CAUTION MODE UNLESS UTILIZED FOR A MERGING TAPER. ARROW PANELS SET IN THE FLASHING ARROW MODE SHALL NOT BE UTILIZED FOR LANE SHIFTS.
- TEMPORARY CONSTRUCTION SIGNS AND OTHER WORKZONE TRAFFIC CONTROL DEVICES THAT ARE DAMAGED OR REQUIRE RELOCATION SHALL BE REPLACED AND / OR RELOCATED UNDER THE PAY ITEM FOR "MAINTENANCE AND MOVEMENT TRAFFIC PROTECTION."
- THE PRIVATE VEHICLES OF CONSTRUCTION WORKERS SHALL NOT BE PARKED ON THE TRAVEL LANES OR SHOULDERS. THEY MAY BE PARKED WITHIN THE STATE RIGHT-OF-WAY ONLY IN AREAS 30' BEYOND THE OUTSIDE EDGE OF THE TRAVEL LANES AND/OR IN AREAS APPROVED BY THE ENGINEER.
- TEMPORARY CONSTRUCTION SIGNS AND OTHER TEMPORARY TRAFFIC CONTROL DEVICES SHALL BE INSTALLED PRIOR TO THE START OF WORK IN ANY AREA OPEN TO TRAFFIC, AND SHALL BE REMOVED AS SOON AS PRACTICAL WHEN THEY ARE NO LONGER APPROPRIATE.
- THE INTENDED VEHICLE PATHS THROUGH EACH WORK ZONE SHALL BE CLEARLY MARKED AT ALL TIMES. WATERBORNE PAVEMENT MARKINGS SHALL BE INSTALLED BEFORE THE END OF THE WORK SHIFT ON ALL COLD-PLANNED AND NEW ROADWAY SURFACES THAT WILL BE OPENED TO TRAFFIC AT THE END OF THE SHIFT.

DEPARTMENT OF ENVIRONMENTAL MANAGEMENT  
 OFFICE OF WATER RESOURCES  
 FRESHWATER WETLANDS PROGRAM  
 APPROVED WITH CONDITIONS  
 AS SPECIFIED IN THE LETTER OF APPROVAL  
 DATED DEC 19 2017 FILE: 17-0275  
 NO CHANGES ALLOWED WITHOUT WRITTEN APPROVAL  
 APPROVED PLANS MUST BE AT CONSTRUCTION SITE

*Charles A. Harte*

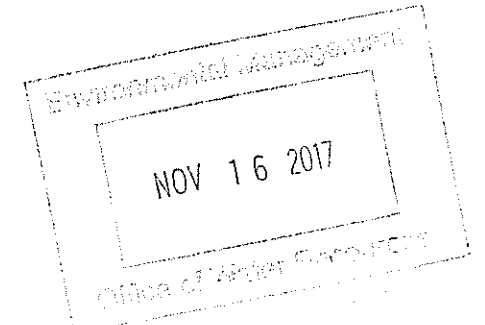

**PERMITTING SET ONLY  
 NOT FOR CONSTRUCTION**

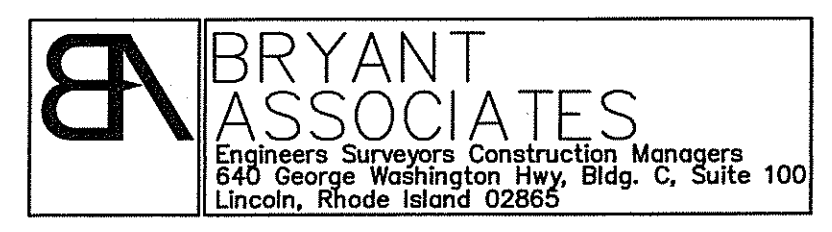

RHODE ISLAND  
 DEPARTMENT OF TRANSPORTATION

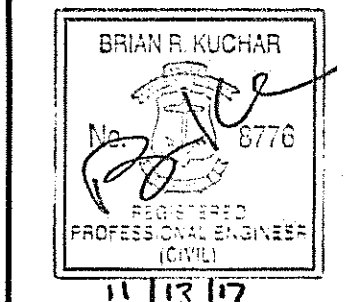

DESIGNED BY: GSG  
 CHECKED BY: BRK  
 DATE: 11/13/2017  
 SHEET: 3  
 OF: 11

SCALE: N/A					
REVISIONS			REVISIONS		
NO.	DATE	BY	NO.	DATE	BY

STORMWATER RETROFITS  
 ROGER WILLIAMS PARK - SITE 7A & 7B  
 PROVIDENCE CONTRACT: 00 VOLUME:1 RHODE ISLAND  
 GENERAL NOTES (1)

- SURVEY NOTES:**
1. THE TOPOGRAPHY AND EXISTING SITE DETAIL DEPICTED HEREON WERE OBTAINED FROM AN INSTRUMENT SURVEY CONDUCTED ON THE GROUND BY BRYANT ASSOCIATES. SURVEY WAS PERFORMED MARCH AND APRIL OF THE 2017
  2. THIS PLAN DOES NOT SHOW ANY RECORDED OR UNWRITTEN EASEMENTS WHICH MAY EXIST. HOWEVER, THIS DOES NOT CONSTITUTE A GUARANTEE THAT NO SUCH EASEMENTS EXIST.
  3. THE ELEVATIONS DEPICTED HEREON WERE BASED ON THE NORTH AMERICAN VERTICAL DATUM OF 1988.
  4. EXISTING CONTOUR INTERVALS ARE EQUAL TO ONE FOOT.
  5. THE ACCURACY OF MEASURED PIPE INVERTS AND PIPE SIZES IS SUBJECT TO FIELD CONDITIONS, THE ABILITY TO MAKE VISUAL OBSERVATIONS, DIRECT ACCESS TO THE VARIOUS ELEMENTS AND OTHER CONDITIONS
  6. INSET PLAN WAS NOT SURVEYED. INFORMATION AND PLAN TAKEN FROM RECORD SET "3R IMPROVEMENTS TO R.I. ROUTE 10 - CONTRACT 1"

- SITE 7A BASIC CONSTRUCTION SEQUENCE**  
 THE FOLLOWING CONSTRUCTION SEQUENCE IS TO BE USED AS A GENERAL GUIDELINE. THE CONTRACTOR SHALL COORDINATE WITH RIDOT ENGINEERS, AND LANDSCAPE ARCHITECTS AND SUBMIT A PROPOSED CONSTRUCTION SEQUENCE FOR REVIEW AND APPROVAL PRIOR TO CONSTRUCTION.
1. STAKE OUT LIMIT OF WORK/CLEARING.
  2. INSTALL SESC DEVICES AS SHOWN ON THE PLANS.
  3. SAWCUT EXISTING CONCRETE SWALE AT LOCATION SPECIFIED ON THE PLANS. REMOVE AND DISPOSE OF CONCRETE SWALE.
  4. STRIP TOPSOIL.
  5. EXCAVATE AREA OF SAND FILTER AND FOREBAY.
  6. ROUGH GRADE SITE AND CREATE BERM.
  7. DEPENDING ON SOIL MATERIAL AT BOTTOM OF BED, CONTRACTOR TO REMOVE FURTHER MATERIAL UNTIL SUITABLE MATERIAL IS REACHED. TO BE IDENTIFIED IN THE FIELD THE ENGINEER.
  8. INSTALL FOREBAY.
  9. PLACE SAND IN BED.
  10. INSTALL OF FOREBAY OVERFLOW AND EMERGENCY OVERFLOW SPILLWAY
  11. CONFIRM ROUGH GRADE. ENGINEER FIELD SITE VISIT REQUIRED.
  12. PLACE TOPSOIL AND FINISH GRADING.
  13. INSTALL PLANT SEED.
  14. INSTALL SESC DEVICES ALONG TOE OF FOREBAY AND SAND FILTER UNTIL SEED ESTABLISHMENT.
  15. REMOVAL OF REMAINING ESC DEVICES AND FINAL CLEANUP.

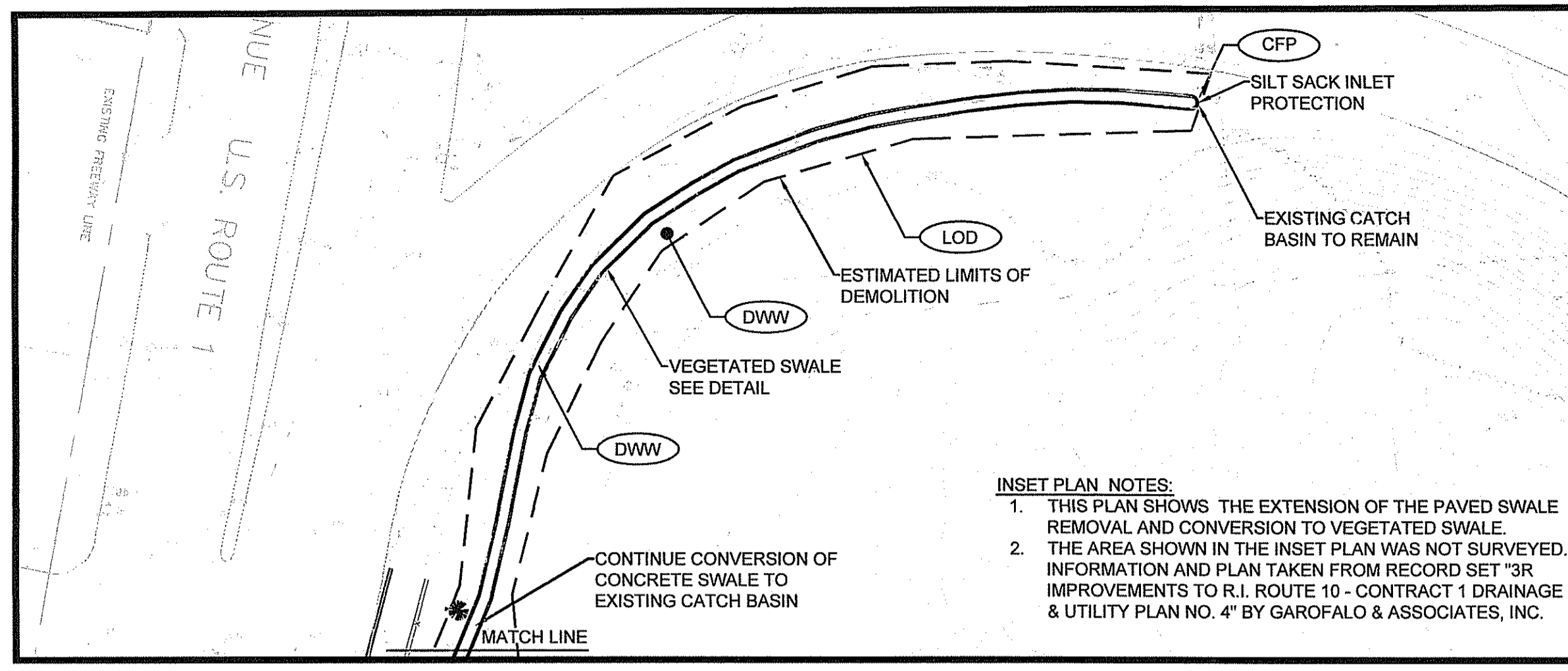

FED. ROAD DIV. NO.	STATE	FEDERAL AID PROJECT NO.	FISCAL YEAR	SHEET NO.	TOTAL SHEETS
*	RI	*	2018	4	11

DEPTH	FILL TYPE	THICKNESS	ELEVATION
0"	TP-1 FILL SANDY FILL	41.5'	
2"	FILL MIXED URBAN RUBBLE	41.3'	
43"	FILL	37.9'	
96"	10 YR 3/1 LOAMY SAND	33.5'	
106"	10 YR 5/4 LOAMY SAND	32.7'	
118"	10 YR 6/6 LOAMY SAND	31.7'	
120"	10 YR 6/6 LOAMY SAND	31.5'	

INFILTRATION TEST PERFORMED IN FILL LAYER 48" FROM SURFACE RATE = 6.5 in/hr

GROUNDWATER NOT ENCOUNTERED

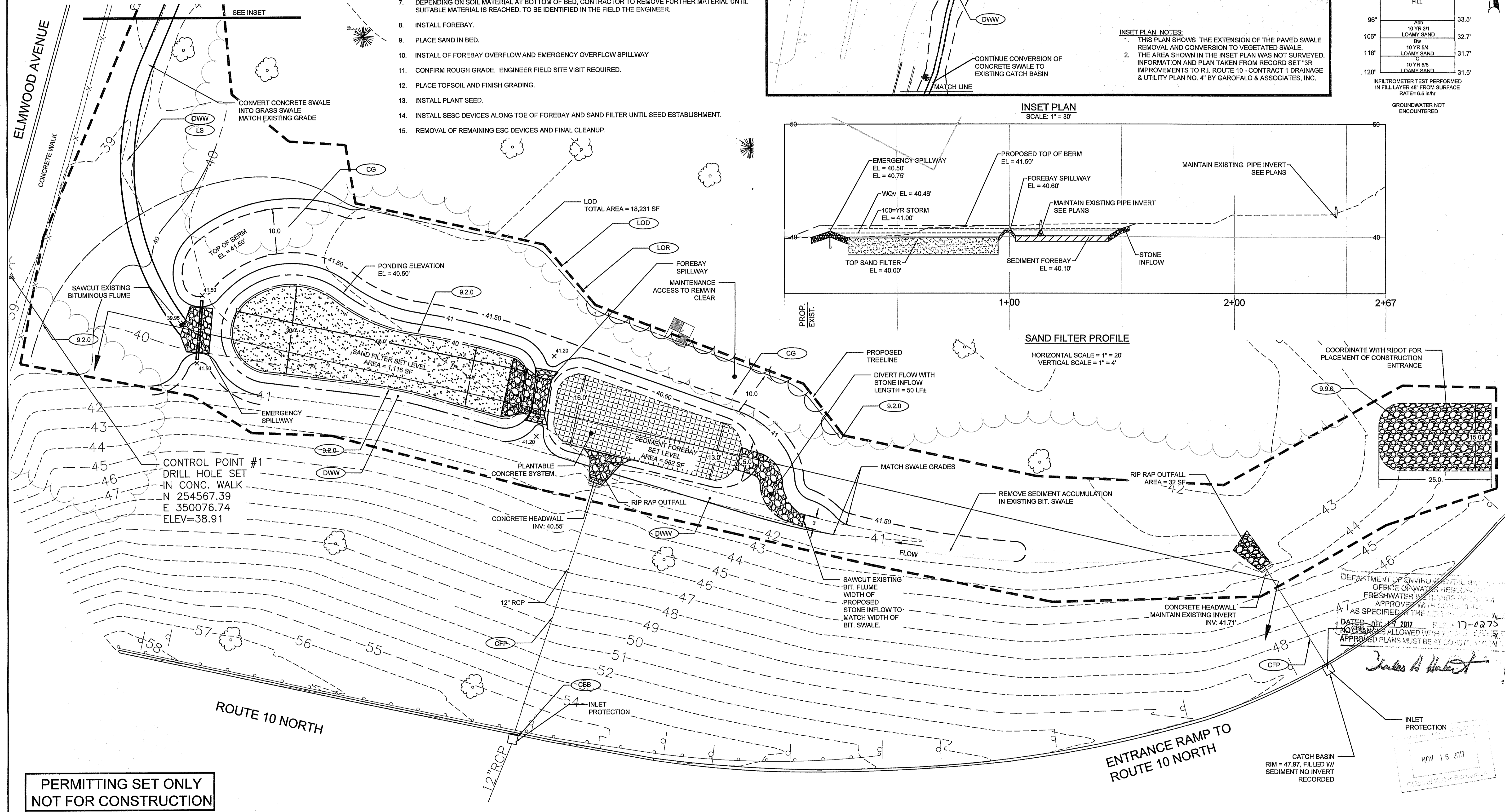

**PERMITTING SET ONLY  
 NOT FOR CONSTRUCTION**

DEPARTMENT OF ENVIRONMENTAL MANAGEMENT  
 OFFICE OF WATER RESOURCES  
 FRESHWATER DIVISION  
 APPROVED WITH COMMENTS  
 AS SPECIFIED IN THE COMMENTS  
 DATED DEC 14 2017 FILE 17-0275  
 NO PERMITS ALLOWED WITHOUT THESE APPROVED PLANS MUST BE AT CONSTRUCTION SITE

*Justin A. Harte*

NOV 16 2017

**BRYANT ASSOCIATES**  
 Engineers Surveyors Construction Managers  
 640 George Washington Hwy, Bldg. C, Suite 100  
 Lincoln, Rhode Island 02865

**Horsley Witten Group, Inc.**  
 Sustainable Environmental Solutions  
 www.horsleywitten.com  
 90 Route 6A  
 Sandwich, MA 02563  
 508-833-6600 voice  
 508-833-3150 fax

**RI DOT** RHODE ISLAND DEPARTMENT OF TRANSPORTATION

**BRIAN R. KUCHAR**  
 PROFESSIONAL ENGINEER  
 11/13/17

DESIGNED BY: GSG  
 CHECKED BY: BRK  
 DATE: 11/13/2017  
 SHEET: 4  
 OF: 11

SCALE: 1" = 10'

REVISIONS					
NO.	DATE	BY	NO.	DATE	BY

**STORMWATER RETROFITS  
 ROGER WILLIAMS PARK-SITE 7A & 7B  
 CONTRACT: 00 VOLUME: 1**

**SITE 7A LAYOUT & GRADING PLAN**

LOCATION: RHODE ISLAND

**SURVEY NOTES:**

1. THE TOPOGRAPHY AND EXISTING SITE DETAIL DEPICTED HEREON WERE OBTAINED FROM AN INSTRUMENT SURVEY CONDUCTED ON THE GROUND BY BRYANT ASSOCIATES. SURVEY WAS PERFORMED MARCH AND APRIL OF THE 2017
2. HORIZONTAL DATUM: RHODE ISLAND STATE PLANE COORDINATES, NAD '83.
3. VERTICAL DATUM: NAVD 1988.
4. THIS PLAN DOES NOT SHOW ANY RECORDED OR UNWRITTEN EASEMENTS WHICH MAY EXIST. HOWEVER, THIS DOES NOT CONSTITUTE A GUARANTEE THAT NO SUCH EASEMENTS EXIST.
5. THE ELEVATIONS DEPICTED HEREON WERE BASED ON THE NORTH AMERICAN VERTICAL DATUM OF 1988.
6. EXISTING CONTOUR INTERVALS ARE EQUAL TO TWO FEET.
7. THE ACCURACY OF MEASURED PIPE INVERTS AND PIPE SIZES IS SUBJECT TO FIELD CONDITIONS, THE ABILITY TO MAKE VISUAL OBSERVATIONS, DIRECT ACCESS TO THE VARIOUS ELEMENTS AND OTHER CONDITIONS

**SITE 7B BASIC CONSTRUCTION SEQUENCE**

THE FOLLOWING CONSTRUCTION SEQUENCE IS TO BE USED AS A GENERAL GUIDELINE. THE CONTRACTOR SHALL COORDINATE WITH THE OWNER, ENGINEERS, AND LANDSCAPE ARCHITECTS AND SUBMIT A PROPOSED CONSTRUCTION SEQUENCE FOR REVIEW AND APPROVAL PRIOR TO CONSTRUCTION.

1. STAKE OUT LIMIT OF WORK.
2. INSTALL ESC DEVICES AROUND PERIMETER OF THE PROPOSED STORMWATER MANAGEMENT AREAS.
3. SELECTIVE DEMOLITION AND TREE REMOVAL (SEE PLAN).
4. SITE CLEARING & GRUBBING.
5. INSTALLATION OF CONCRETE DIVERSION STRUCTURE AND WATER QUALITY UNIT. KEEP OUTLET TO WET SWALE BLOCKED UNTIL ENGINEER IS NOTIFIED
6. STAKE OUT WET SWALE TOP AND BOTTOM OF SLOPE.
7. ROUGH GRADE WET SWALE
8. SAWCUT EXISTING CONCRETE PATH AND TRENCH FOR PIPE.
9. EXCAVATE WET SWALE AND CONSTRUCTION OF WEIRS AND SPILLWAYS.
10. INSTALL SESC DEVICES AT SURFACE STORMWATER MANAGEMENT AREAS.
11. SURFACE STABILIZATION (VEGETATION, GRAVEL, RIPRAP, OR OTHER).
12. PATCH PAVEMENT WHERE THE PIPE WAS INSTALLED
13. PLANTING AND FINAL STABILIZATION.
14. REMOVAL OF REMAINING ESC DEVICES AND FINAL CLEANUP.

FED. ROAD DIV. NO.	STATE	FEDERAL AD PROJECT NO.	FISCAL YEAR	SHEET NO.	TOTAL SHEETS
*	RI	*	2018	5	11

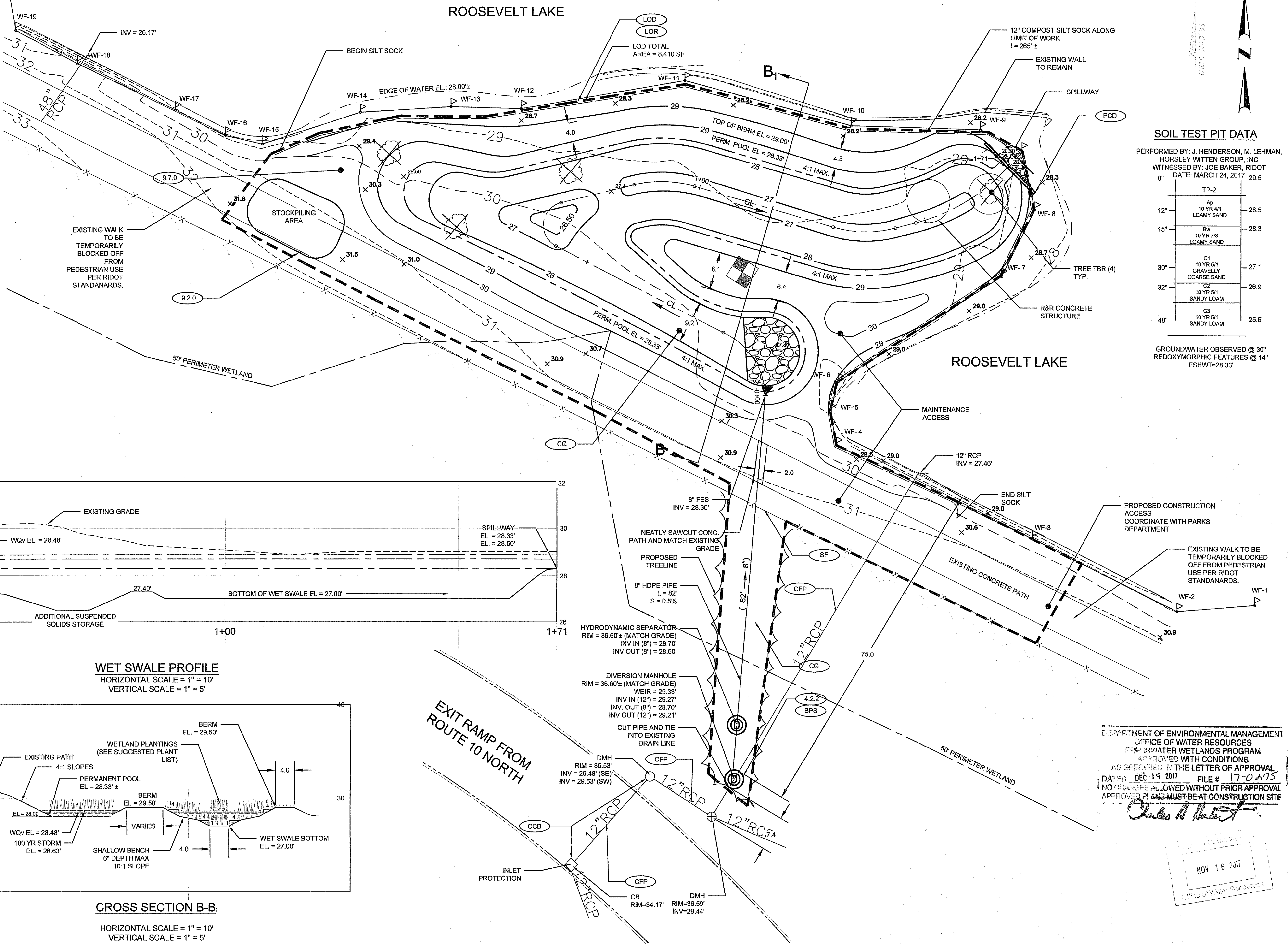

**SOIL TEST PIT DATA**

PERFORMED BY: J. HENDERSON, M. LEHMAN, HORSLEY WITTEN GROUP, INC  
 WITNESSED BY: JOE BAKER, RIDOT  
 DATE: MARCH 24, 2017

DEPTH	SOIL TYPE	ELEVATION
0"	TP-2	29.5'
12"	A <sub>9</sub> 10 YR 4/1 LOAMY SAND	28.5'
15"	B <sub>w</sub> 10 YR 7/3 LOAMY SAND	28.3'
30"	C <sub>1</sub> 10 YR 5/1 GRAVELLY COARSE SAND	27.1'
32"	C <sub>2</sub> 10 YR 6/1 SANDY LOAM	26.9'
48"	C <sub>3</sub> 10 YR 5/1 SANDY LOAM	25.6'

GROUNDWATER OBSERVED @ 30"  
 REDOXYMORPHIC FEATURES @ 14"  
 ESHWT=28.33'

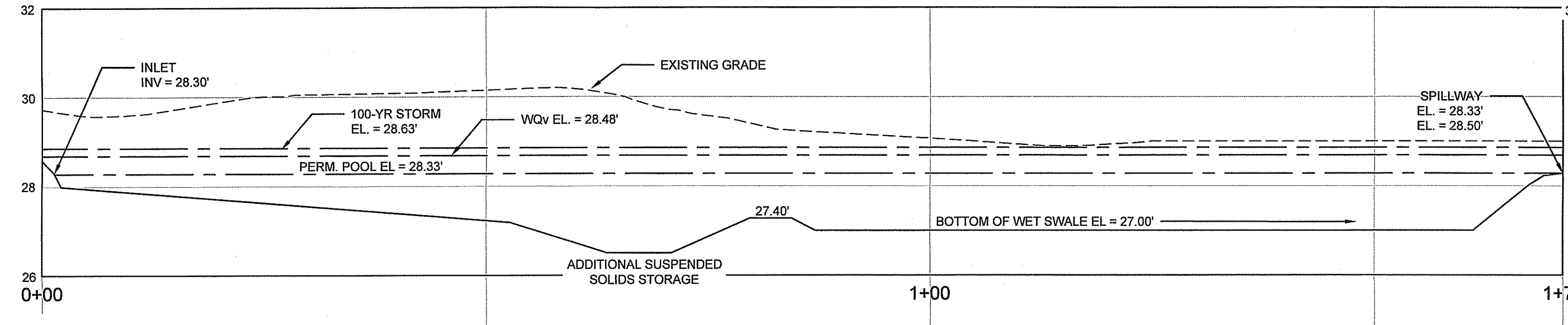

**WET SWALE PROFILE**  
 HORIZONTAL SCALE = 1" = 10'  
 VERTICAL SCALE = 1" = 5'

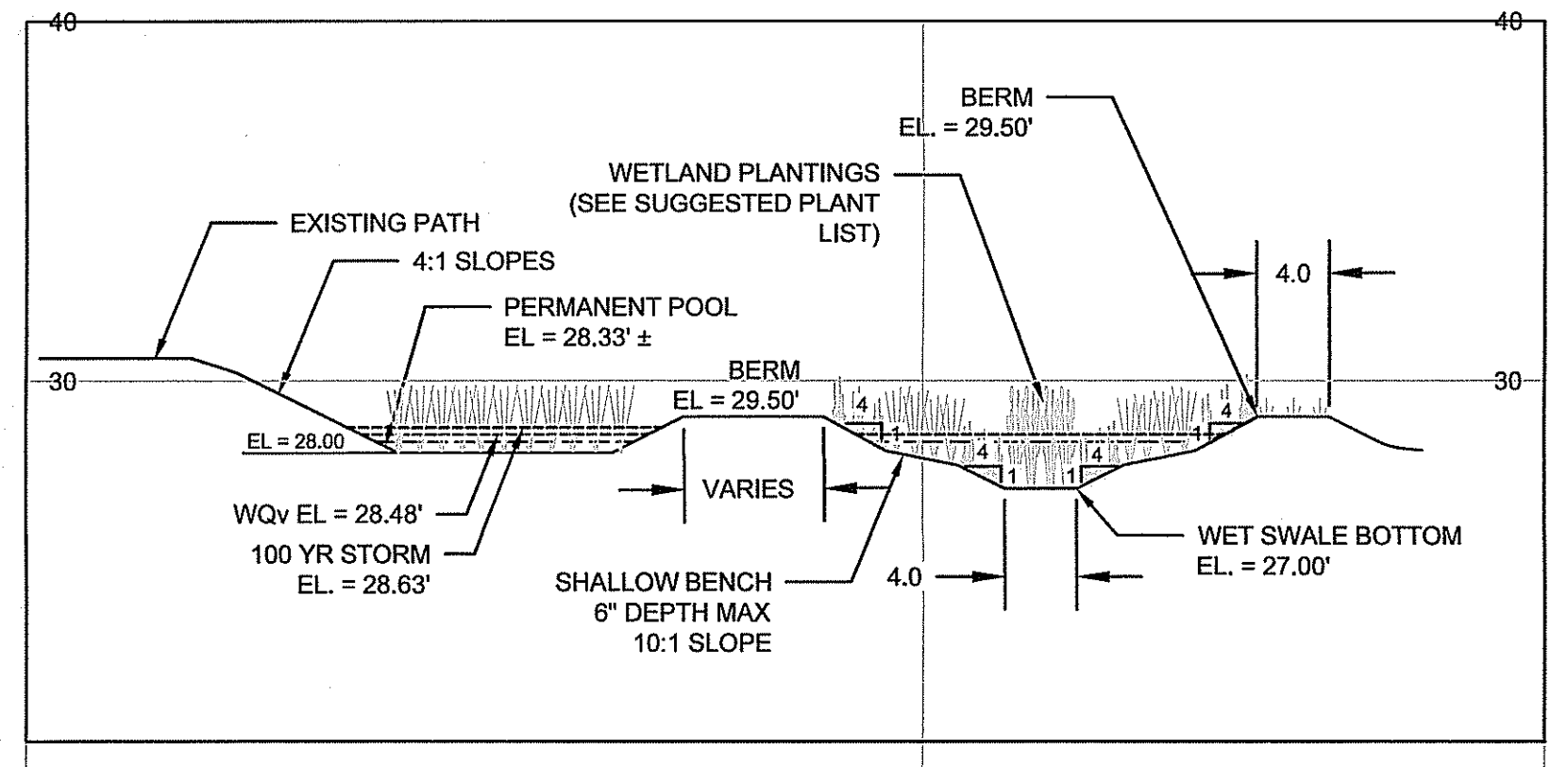

**CROSS SECTION B-B**  
 HORIZONTAL SCALE = 1" = 10'  
 VERTICAL SCALE = 1" = 5'

**PERMITTING SET ONLY  
 NOT FOR CONSTRUCTION**

**BRYANT ASSOCIATES**  
 Engineers Surveyors Construction Managers  
 840 George Washington Hwy. Bldg. C, Suite 100  
 Lincoln, Rhode Island 02865

**Horsley Witten Group, Inc.**  
 Sustainable Environmental Solutions  
 www.horsleywitten.com  
 90 Route 6A  
 Sandwich, MA 02563  
 508-833-6600 voice  
 508-833-3150 fax

**RI DOT**  
 RHODE ISLAND  
 DEPARTMENT OF TRANSPORTATION

**BRIAN R. KUCHAR**  
 PROFESSIONAL ENGINEER  
 11/13/17

DESIGNED BY: GSG  
 CHECKED BY: BRK  
 DATE: 11/13/2017  
 SHEET: 5  
 OF: 11

SCALE: 1"=10'  
 GRAPHIC SCALE

REVISIONS			REVISIONS		
NO.	DATE	BY	NO.	DATE	BY

**STORMWATER RETROFITS**  
**ROGER WILLIAMS PARK-SITES 7A & 7B**  
 CONTRACT: 00 VOLUME: 1 RHODE ISLAND

**SITE 7B LAYOUT & GRADING PLAN**

DEPARTMENT OF ENVIRONMENTAL MANAGEMENT  
 OFFICE OF WATER RESOURCES  
 FRESHWATER WETLANDS PROGRAM  
 APPROVED WITH CONDITIONS  
 AS SPECIFIED IN THE LETTER OF APPROVAL  
 DATED DEC 19 2017 FILE # 17-0275  
 NO CHANGES ALLOWED WITHOUT PRIOR APPROVAL  
 APPROVED PLANS MUST BE AT CONSTRUCTION SITE

*Charles A. Hubert*

NOV 16 2017  
 Office of Water Resources

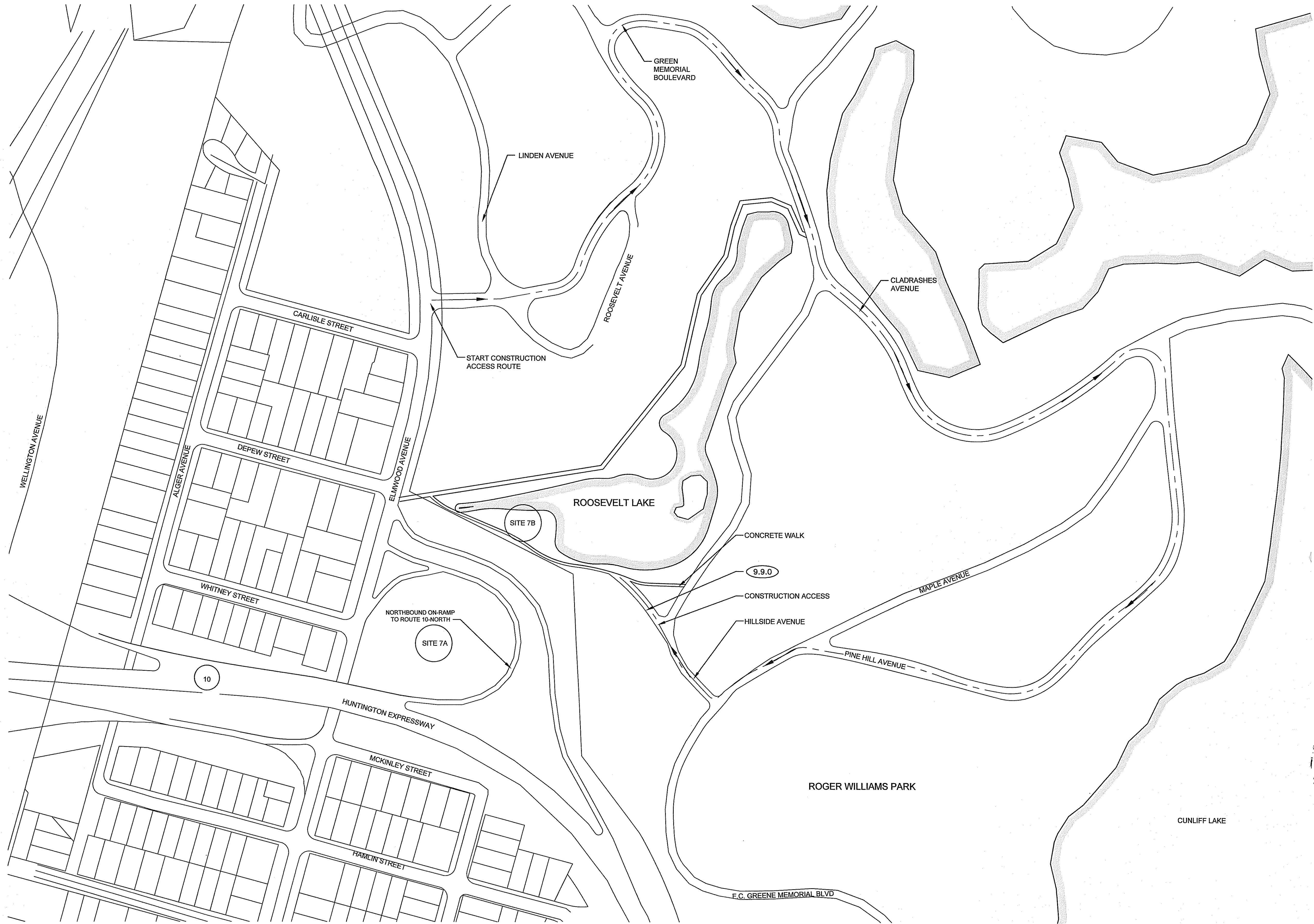

DEPARTMENT OF ENVIRONMENTAL MANAGEMENT  
 OFFICE OF WATER RESOURCES  
 FRESHWATER WETLANDS PROGRAM  
 APPROVED WITH CONDITIONS  
 AS SPECIFIED IN THE LETTER OF APPROVAL  
 DATED - DEC 14 2017 FILE # 17-0275  
 NO CHANGES ALLOWED WITHOUT PRIOR APPROVAL  
 APPROVED PLANS MUST BE AT CONSTRUCTION SITE

*Charles A. Haber*

NOV 16 2017  
 Office of Water Resources

PERMITTING SET ONLY  
 NOT FOR CONSTRUCTION

CONSTRUCTION ACCESS MAP  
 SCALE - 1" = 120'

**BRYANT ASSOCIATES**  
 Engineers Surveyors Construction Managers  
 840 George Washington Hwy. Bldg. C, Suite 100  
 Lincoln, Rhode Island 02885

**Horsley Witten Group, Inc.**  
 Sustainable Environmental Solutions  
 www.horsleywitten.com  
 90 Route 6A  
 Sandwich, MA 02563  
 508-833-6600 voice  
 508-833-3150 fax



RHODE ISLAND  
 DEPARTMENT OF TRANSPORTATION

BRIAN R. KUCHAR  
 PROFESSIONAL ENGINEER  
 11/13/17

DESIGNED BY: GSG  
 CHECKED BY: BRK  
 DATE: 11/13/2017  
 SHEET: 6  
 OF: 11

SCALE: 1" = 120'

REVISIONS					
NO.	DATE	BY	NO.	DATE	BY

STORMWATER RETROFITS  
 ROGER WILLIAMS PARK-SITES 7A & 7B  
 CONTRACT: 00 VOLUME: 1  
 LOCATION: RHODE ISLAND  
**CONSTRUCTION ACCESS MAP**

FED. ROAD DIV. NO.	STATE	FEDERAL AID PROJECT NO.	FISCAL YEAR	SHEET NO.	TOTAL SHEETS
00	RI	----	2018	7	11

OUTLET	Do (IN)	d50	D (IN)	H (IN)	X (FT)	Y (FT)	Z (FT)
1	12	6	12	6	2.5	4	7
2	12	6	12	6	2.5	4	8

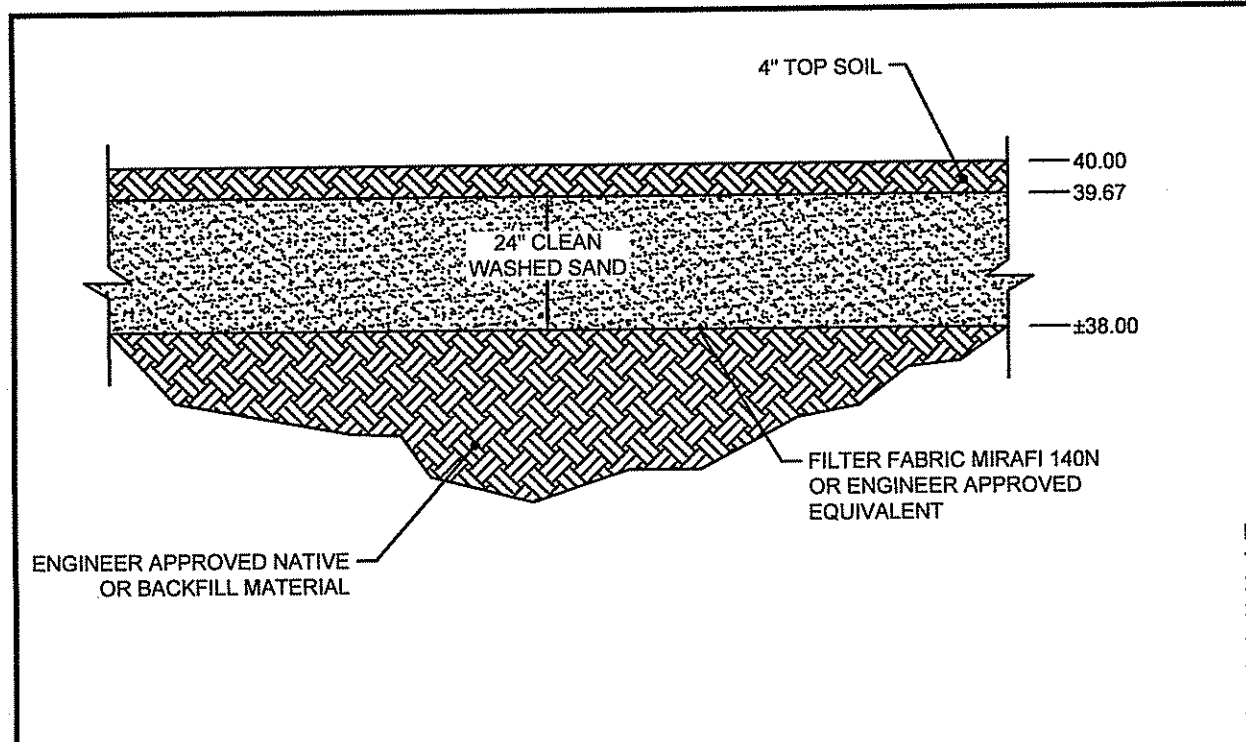

**SAND FILTER**  
NOT TO SCALE

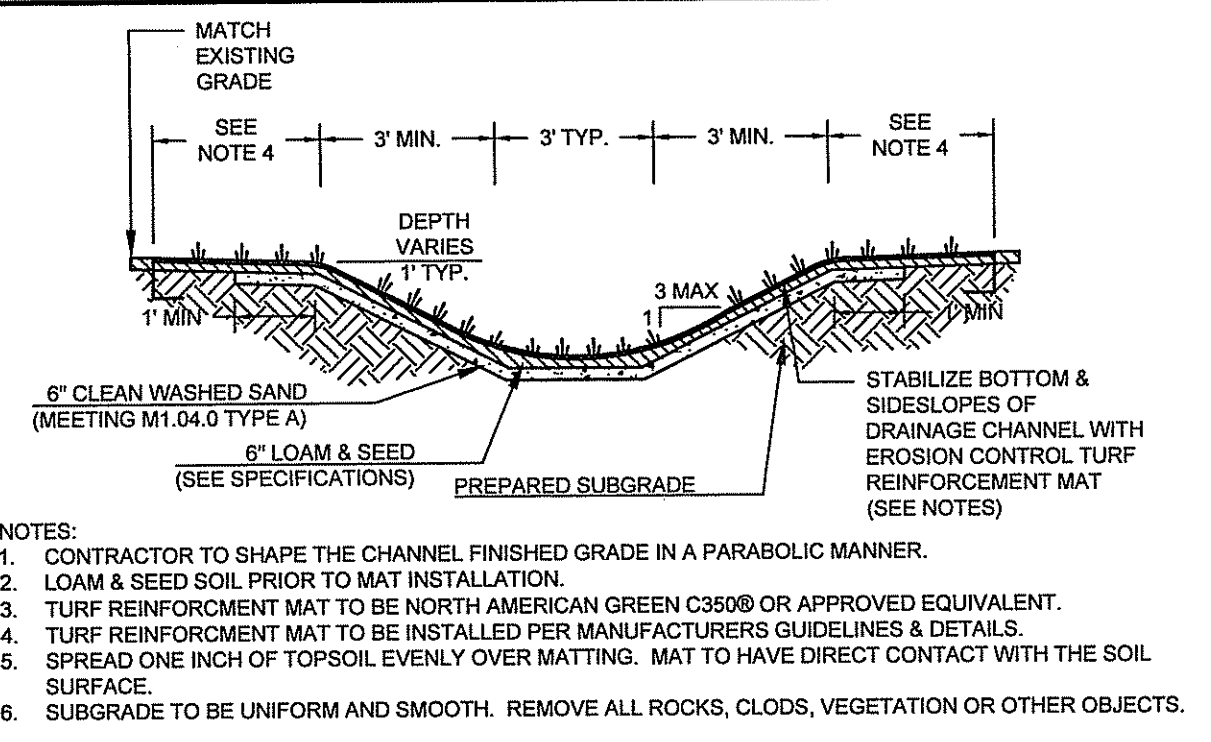

**REINFORCED VEGETATED SWALE**  
NOT TO SCALE

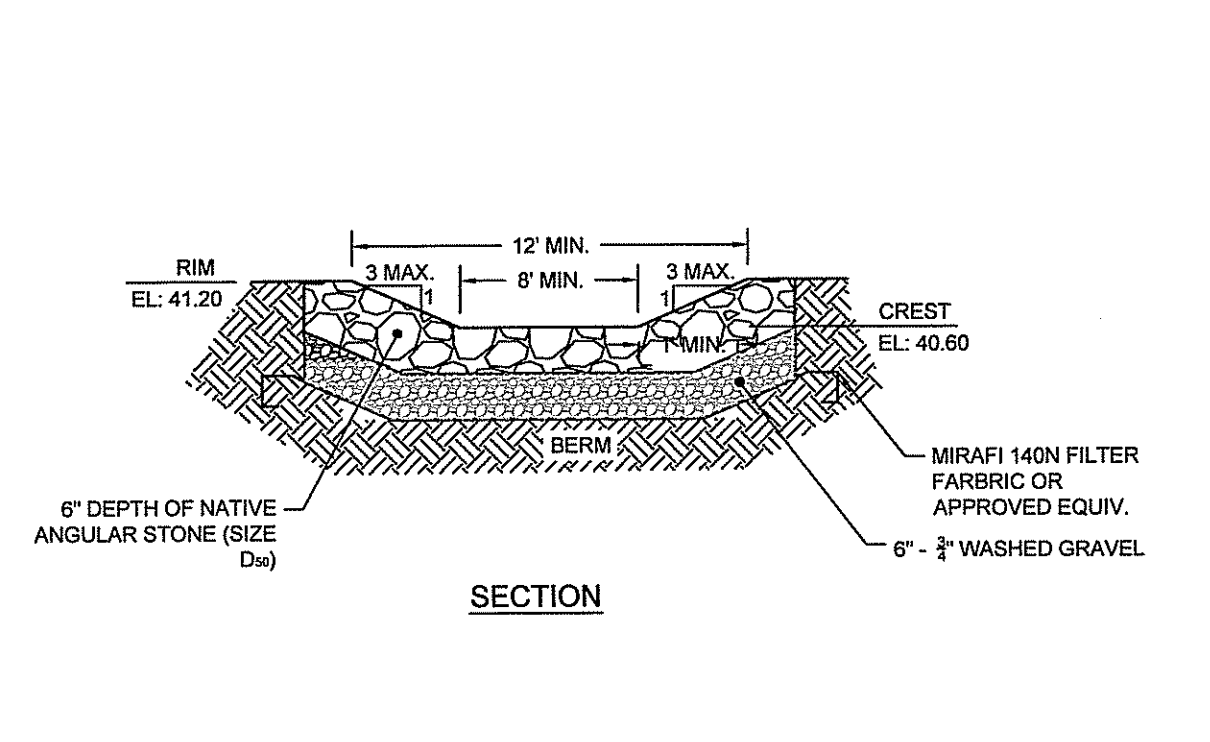

**SECTION**

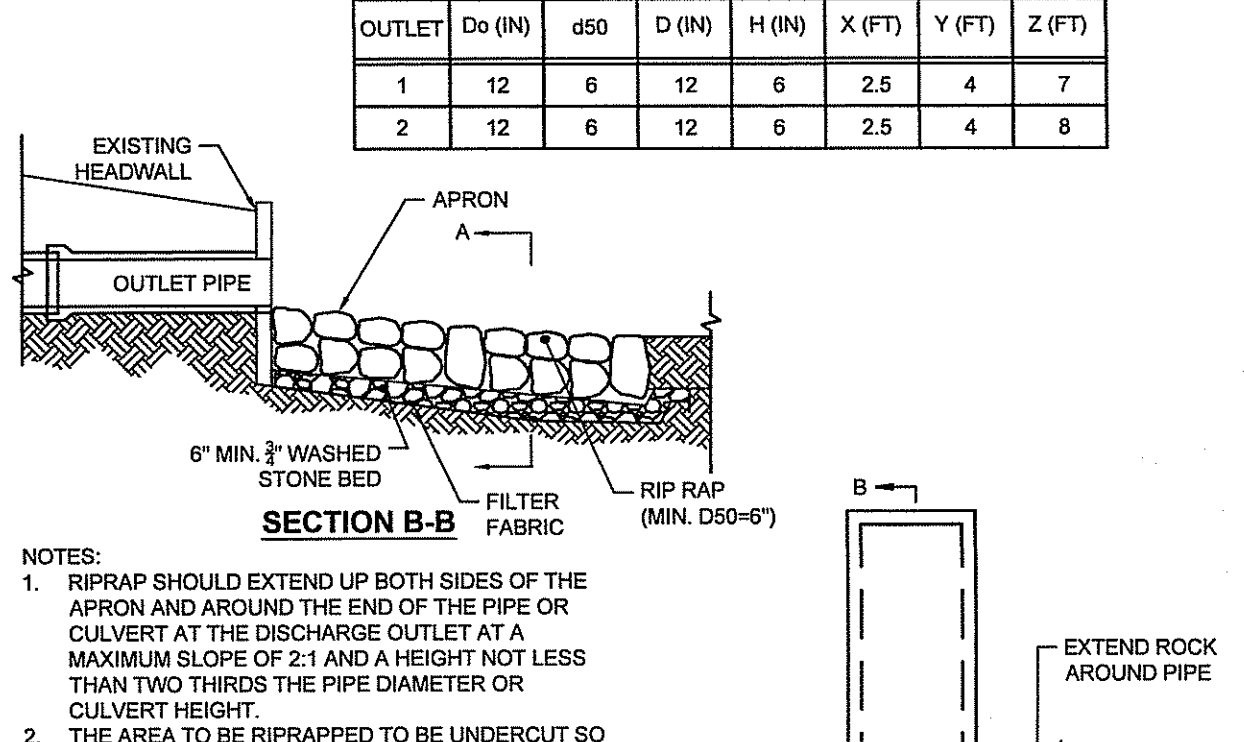

**SECTION B-B**

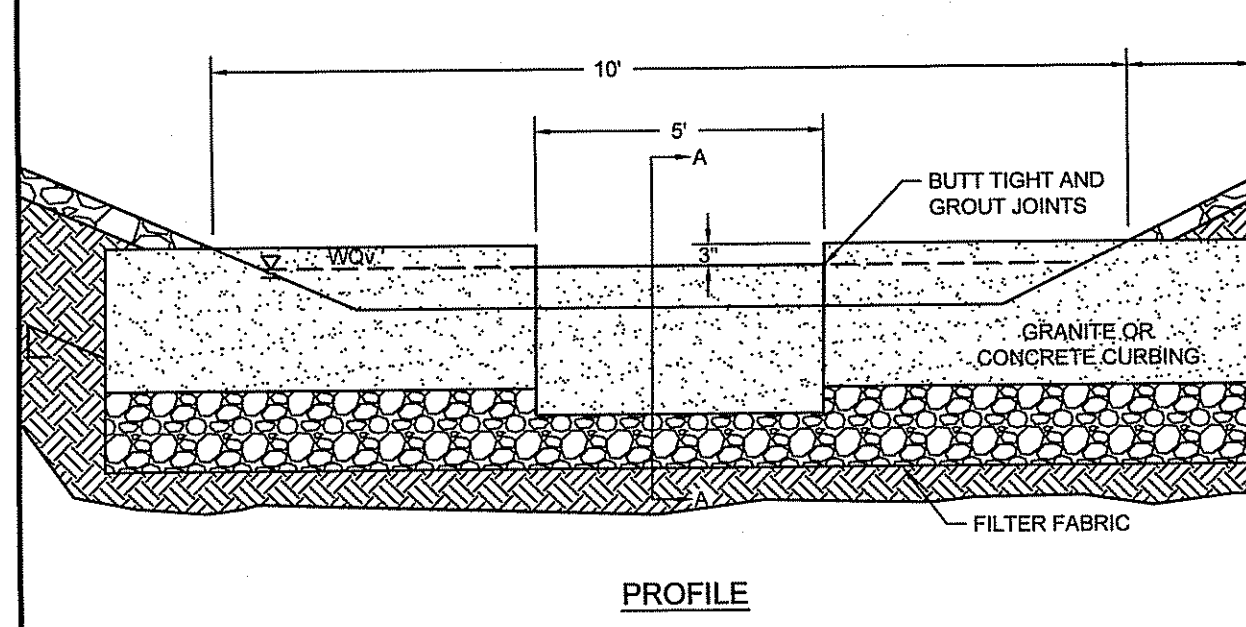

**PROFILE**

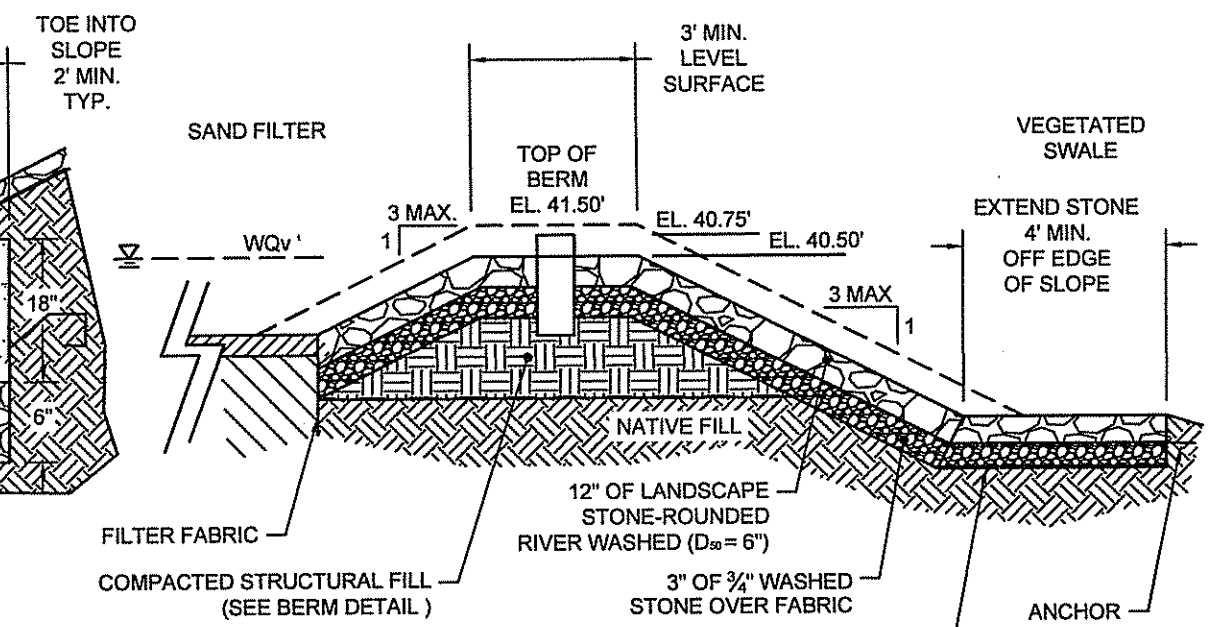

**SAND FILTER SPILLWAY**  
NOT TO SCALE

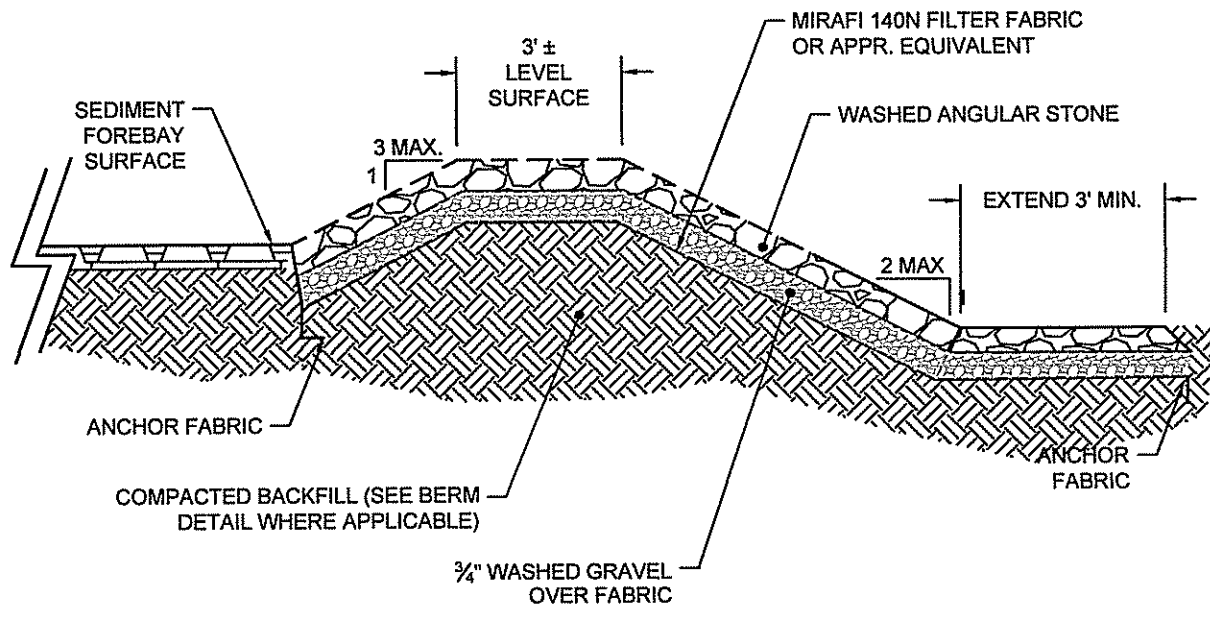

**FOREBAY SPILLWAY**  
NOT TO SCALE

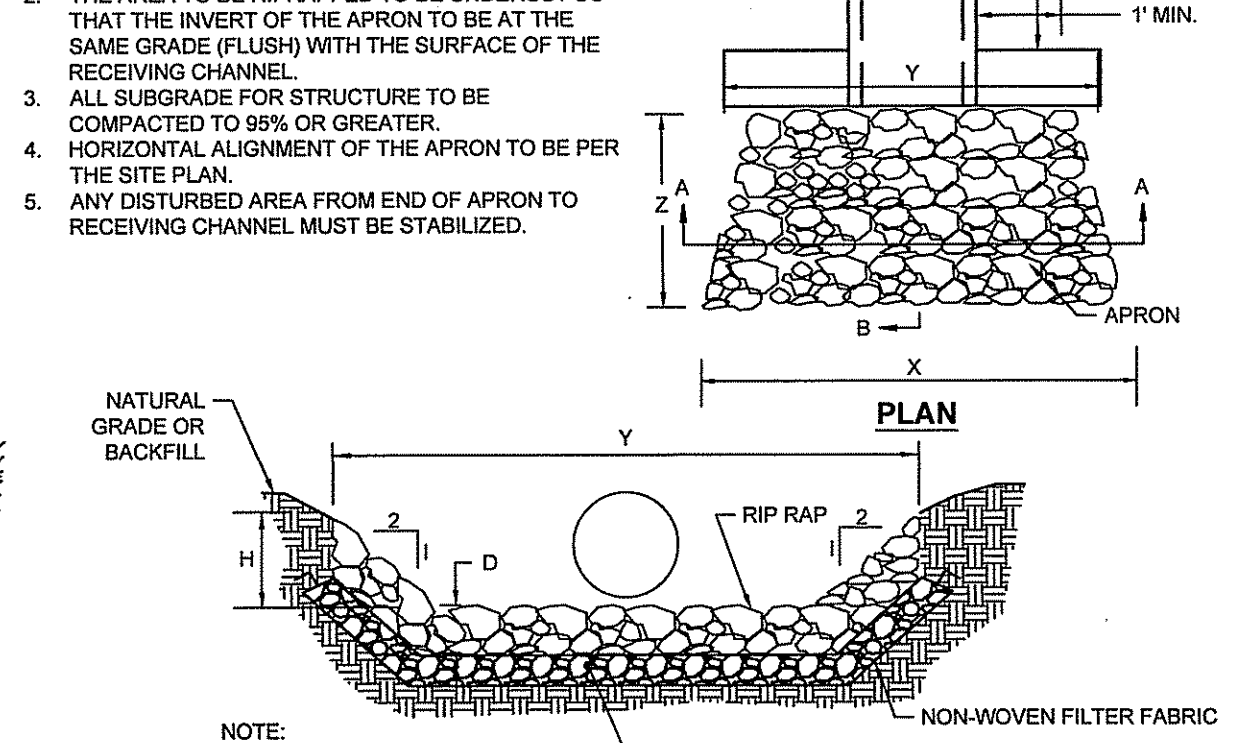

**SECTION A-A**

**RIP RAP OUTFALL**  
NOT TO SCALE

- NOTE:
1. KEY CURBING INTO THE FOREBAY BANKS AND EXTEND INTO THE ADJUTMENTS A MINIMUM OF 2' TO PREVENT FLOW FROM DIVERTING THE CHECK DAM.
  2. GROUT ABUTTING SECTIONS OF CURBING.
  3. STONE IN SPILLWAY CHANNEL TO BE SET LEVEL WITH TOP OF GRANITE OR CONCRETE CURB.
  4. KEY CURB A MINIMUM OF 2' INTO COMPACTED BERM TO PREVENT FLOW DIVERSION.

- NOTES:
1. VEGETATIVE COVER: GRASS SHALL BE NEW ENGLAND EROSION CONTROL/RESTORATION MIX OR APPROVED EQUAL.
  2. LOAM MATERIAL: THE LOAM MATERIAL SHALL CONSIST OF 60-70% WASHED SCREENED SAND, 20-30% TOPSOIL, AND 10-20% ORGANIC MATTER. THE LOAM MATERIAL SHALL BE MIXED TO A UNIFORM CONSISTENCY.
  3. TOPSOIL SHALL BE FREE OF SUB-SOIL, LARGE STONES, EARTH CLODS, STICKS, STUMPS, CLAY LUMPS, ROOTS, OR OTHER OBJECTIONABLE MATTER. TOPSOIL SHALL ALSO BE FREE OF NOXIOUS WEEDS. TOPSOIL SHALL NOT HAVE A pH FACTOR OF LESS THAN 6.0 OR GREATER THAN 7.0.
  4. BERM/BANKMENT FILL (LOW PERMEABILITY MATERIAL): FREE OF ROOTS, STUMPS, WOOD, RUBBISH, AND STONES GREATER THAN 6 INCHES, FROZEN OR OTHER OBJECTIONABLE MATERIALS. CONFORMING TO ASTM D2487 UNIFIED SOIL CLASSIFICATION GC, SC, CH, CL, ML, OR SM WITH AT LEAST 20 PERCENT PASSING THE NO.200 SIEVE.

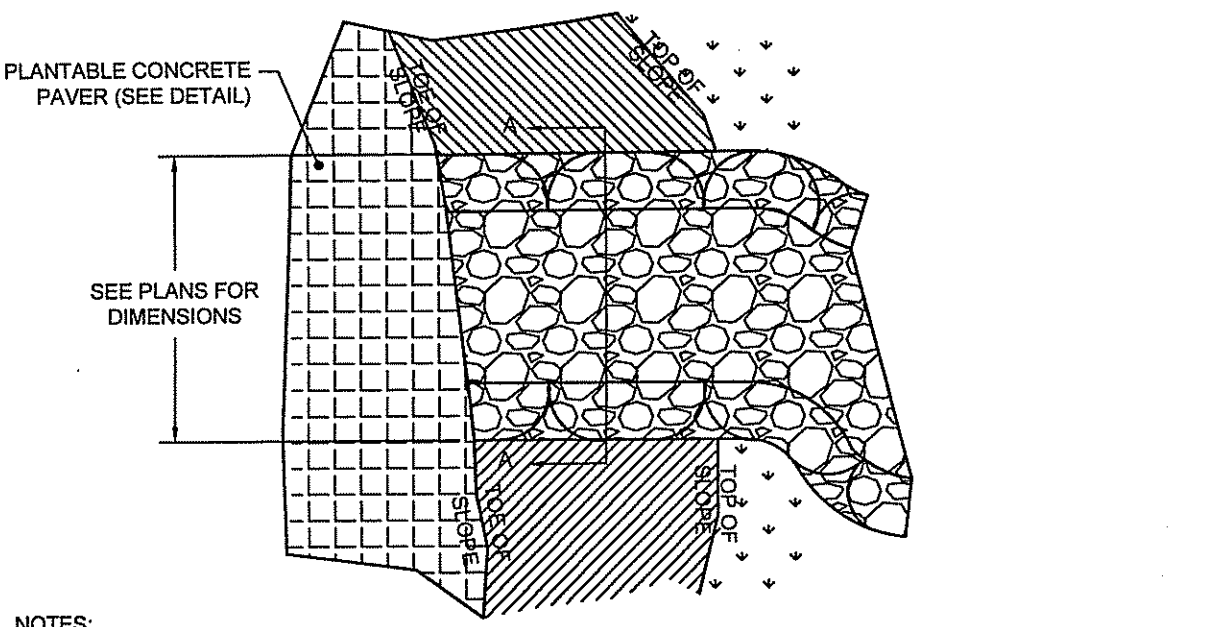

**CHANNEL SECTION**

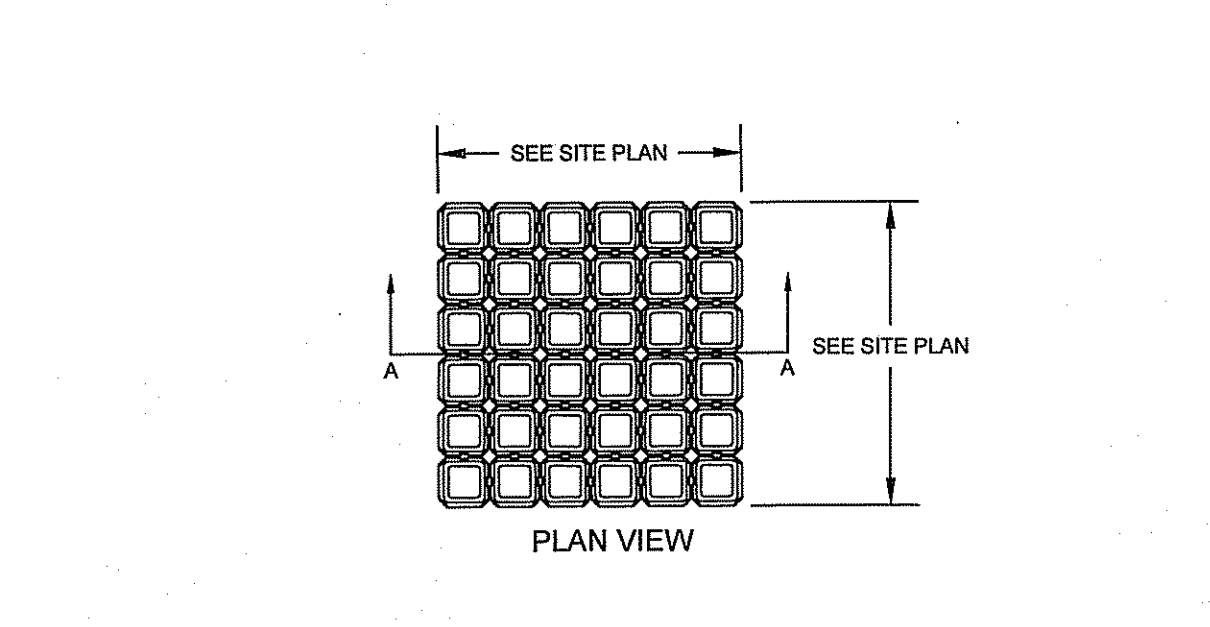

**PLAN VIEW**

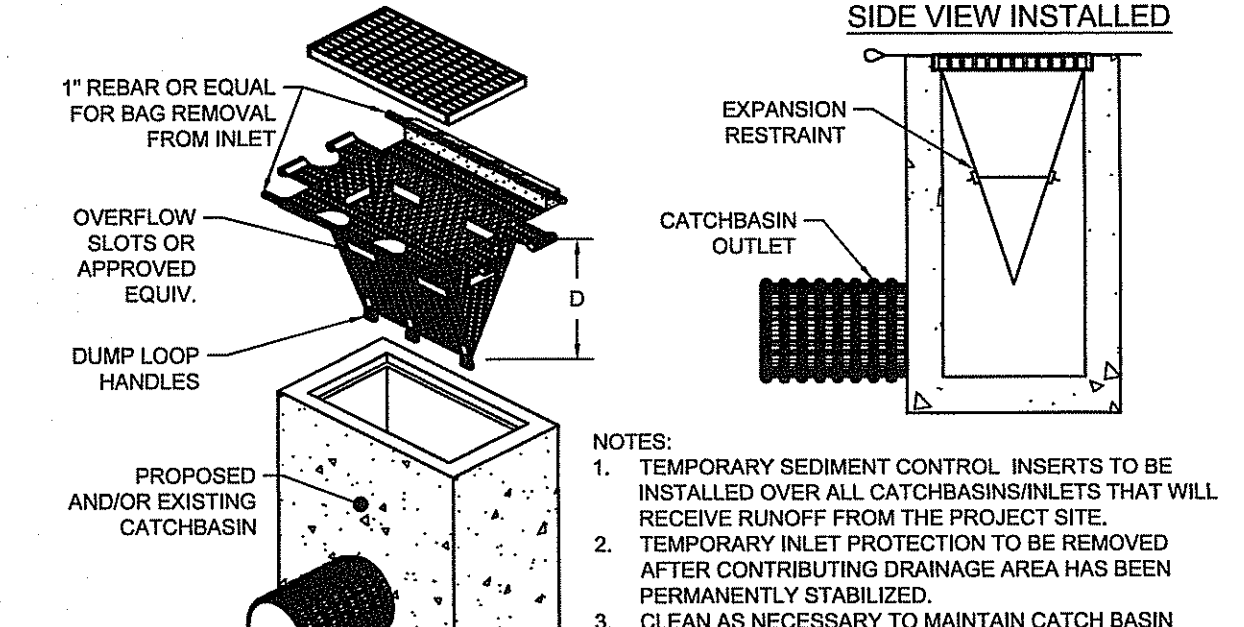

**INLET PROTECTION**  
NOT TO SCALE

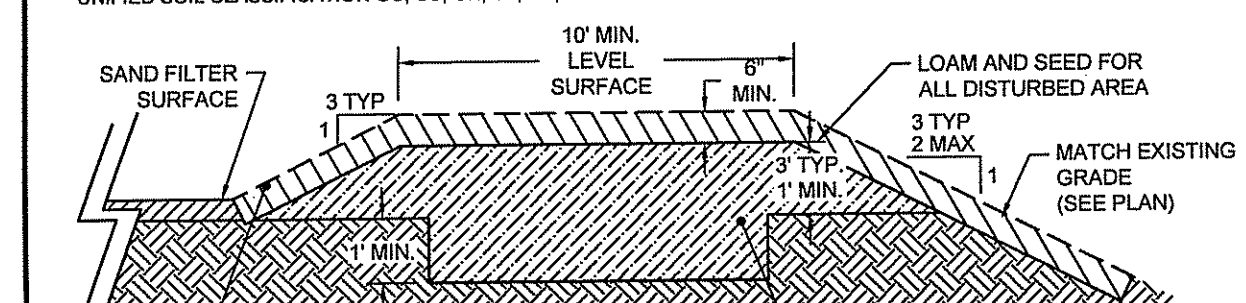

**SAND FILTER BERM**  
NOT TO SCALE

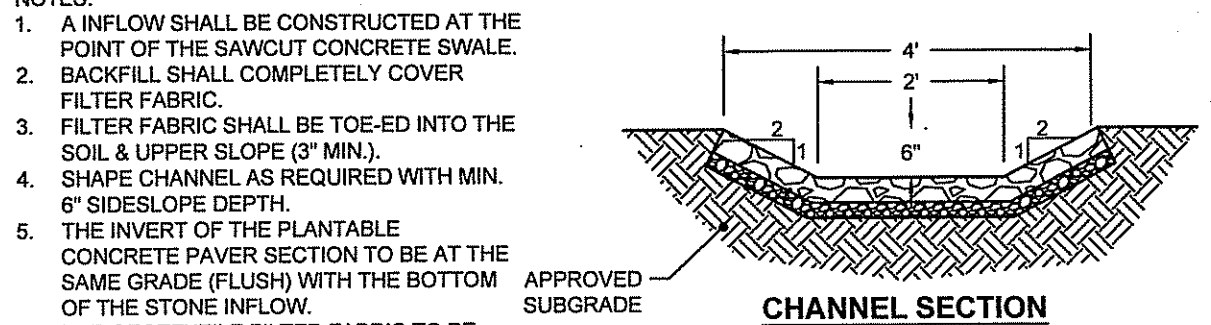

**SECTION**

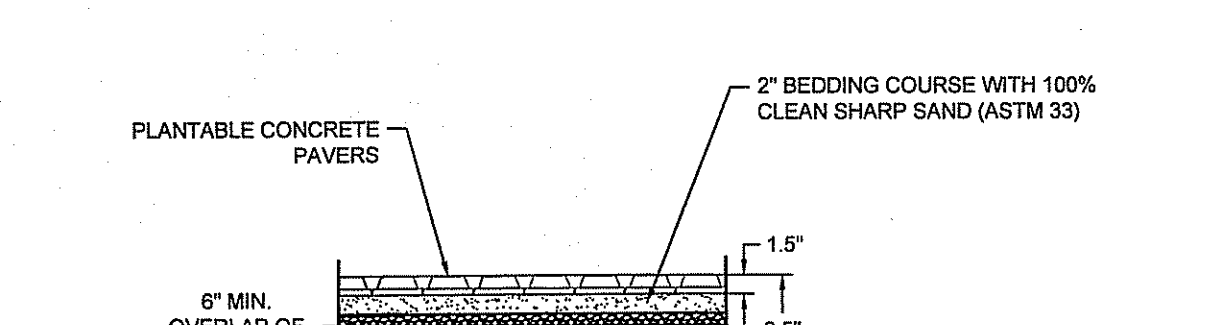

**SECTION A-A**

**CONCRETE GRASS PAVER BLOCKS**  
NOT TO SCALE

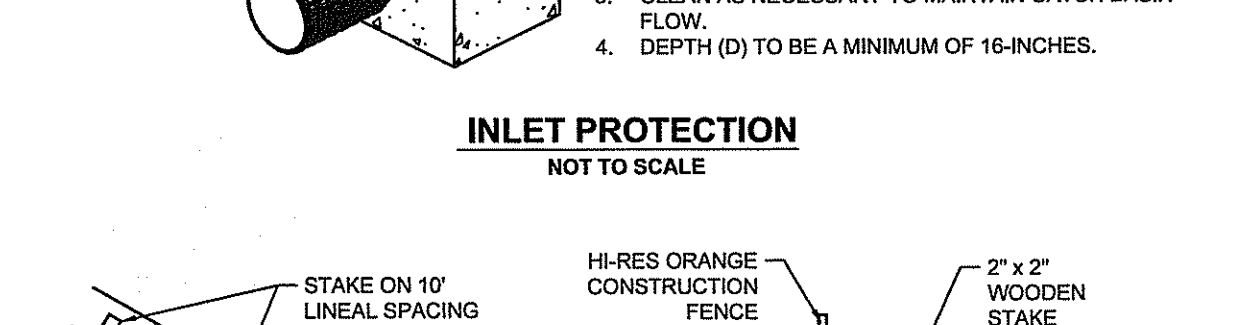

**SEDIMENT SILT SOCK**  
NOT TO SCALE

- NOTES:
1. A INFLOW SHALL BE CONSTRUCTED AT THE POINT OF THE SAWCUT CONCRETE SWALE. BACKFILL SHALL COMPLETELY COVER FILTER FABRIC.
  2. FILTER FABRIC SHALL BE TOE-ED INTO THE SOIL & UPPER SLOPE (2' MIN.).
  3. SHAPE CHANNEL AS REQUIRED WITH MIN. 6" SIDESLOPE DEPTH.
  4. THE INVERT OF THE PLANTABLE CONCRETE PAVES SECTION TO BE AT THE SAME GRADE (FLUSH) WITH THE BOTTOM OF THE STONE INFLOW.
  5. THE GEOTEXTILE FILTER FABRIC TO BE MIRAFI 140N OR EQUIVALENT.

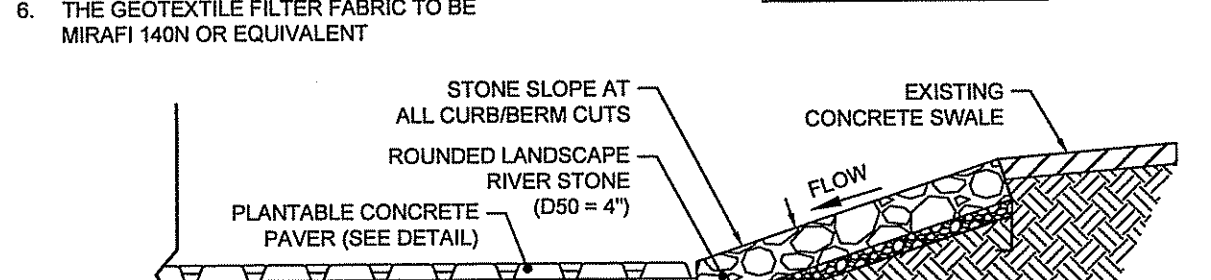

**SAND FILTER INFLOW**  
NOT TO SCALE

- NOTES:
1. MATERIAL SHALL BE PLANTABLE (GRASS) CONCRETE PAVES BLOCKS OR MAT SYSTEM WITH 60% VOID SPACE OR APPROVED EQUIVALENT.
  2. INFILL VOIDS BETWEEN CONCRETE UNITS WITH BEDDING COURSE SAND AND TOPSOIL.
  3. FILTER FABRIC AROUND PERIMETER AND BOTTOM OF STONE BASE. KEY IN MINIMUM 6".

- NOTES:
1. SILT SOCK MANUFACTURER TO BE SILT SOCK OR ENGINEER APPROVED EQUAL.
  2. ALL MATERIAL TO MEET MANUFACTURER'S SPECIFICATIONS.
  3. SEDIMENT SILT SOCK TO BE FILLED WITH LEAF COMPOST AND/OR WOODY MULCH PER MANUFACTURER'S REQUIREMENTS.
  4. FOLLOWING CONSTRUCTION AND SITE STABILIZATION, COMPOST MATERIAL TO BE REMOVED OR DISPERSED ON SITE, AS APPROVED BY THE ENGINEER.

DEPARTMENT OF ENVIRONMENTAL MANAGEMENT  
OFFICE OF WATER RESOURCES  
FRESHWATER WETLANDS PROGRAM  
APPROVED WITH CONDITIONS  
AS SPECIFIED IN THE LETTER OF APPROVAL  
DATED DEC 19 2017 FILE # 17-0375  
NO CHANGES ALLOWED WITHOUT PRIOR APPROVAL  
APPROVED PLANS MUST BE AT CONSTRUCTION SITE

*Charles A. Harte*

NOV 16 2017  
Office of Water Resources

PERMITTING SET ONLY  
NOT FOR CONSTRUCTION



**Horsley Witten Group, Inc.**  
Sustainable Environmental Solutions  
www.horsleywitten.com  
90 Route 6A  
Sandwich, MA 02563  
508-833-6600 voice  
508-833-3150 fax

**RI DOT**  
RHODE ISLAND  
DEPARTMENT OF TRANSPORTATION

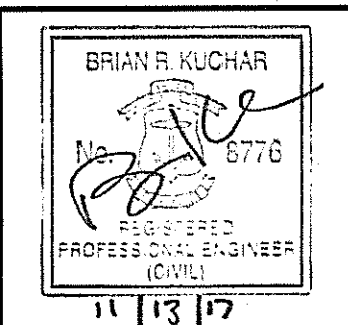

DESIGNED BY: GSG  
CHECKED BY: BRK  
DATE: 11/13/2017  
SHEET: 7  
OF: 11

REVISIONS		REVISIONS	
NO.	DATE	NO.	DATE

SCALE: N/A  
STORMWATER RETROFITS  
ROGER WILLIAMS PARK-SITES 7A & 7B  
CONTRACT: 00 VOLUME: --- RHODE ISLAND  
DETAILS (1)

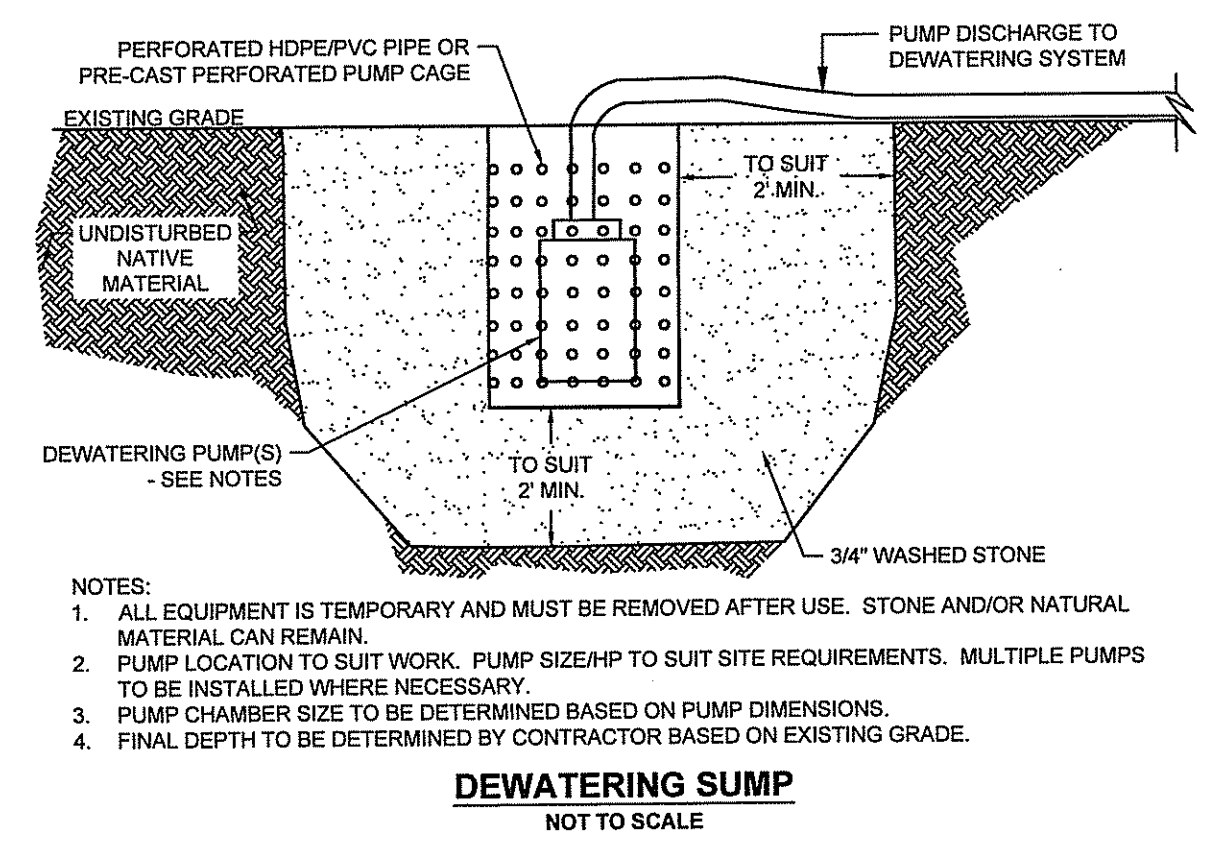

- NOTES:
1. ALL EQUIPMENT IS TEMPORARY AND MUST BE REMOVED AFTER USE. STONE AND/OR NATURAL MATERIAL CAN REMAIN.
  2. PUMP LOCATION TO SUIT WORK. PUMP SIZE/HP TO SUIT SITE REQUIREMENTS. MULTIPLE PUMPS TO BE INSTALLED WHERE NECESSARY.
  3. PUMP CHAMBER SIZE TO BE DETERMINED BASED ON PUMP DIMENSIONS.
  4. FINAL DEPTH TO BE DETERMINED BY CONTRACTOR BASED ON EXISTING GRADE.

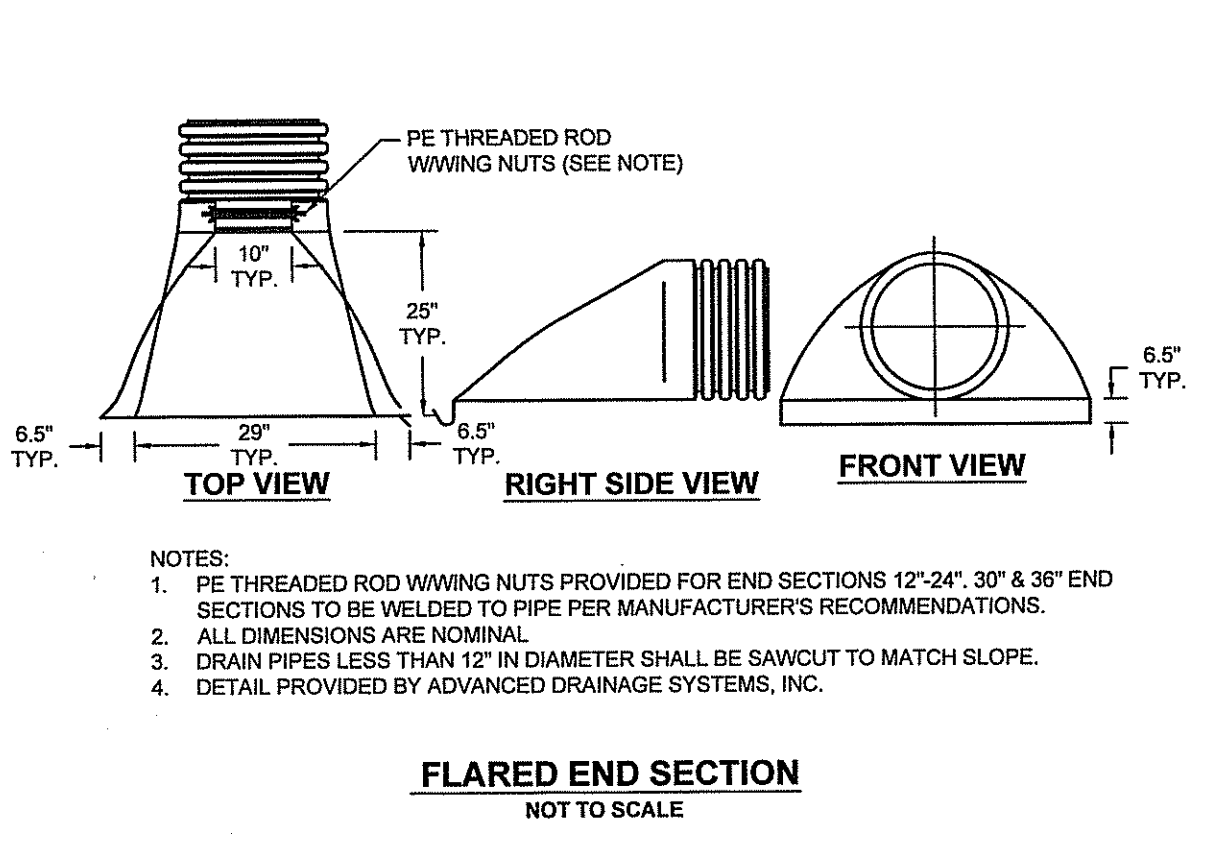

- NOTES:
1. PE THREADED ROD WITH WING NUTS PROVIDED FOR END SECTIONS 12" x 24", 30" x 36" END SECTIONS TO BE WELDED TO PIPE PER MANUFACTURER'S RECOMMENDATIONS.
  2. ALL DIMENSIONS ARE NOMINAL.
  3. DRAIN PIPES LESS THAN 12" IN DIAMETER SHALL BE SAWCUT TO MATCH SLOPE.
  4. DETAIL PROVIDED BY ADVANCED DRAINAGE SYSTEMS, INC.

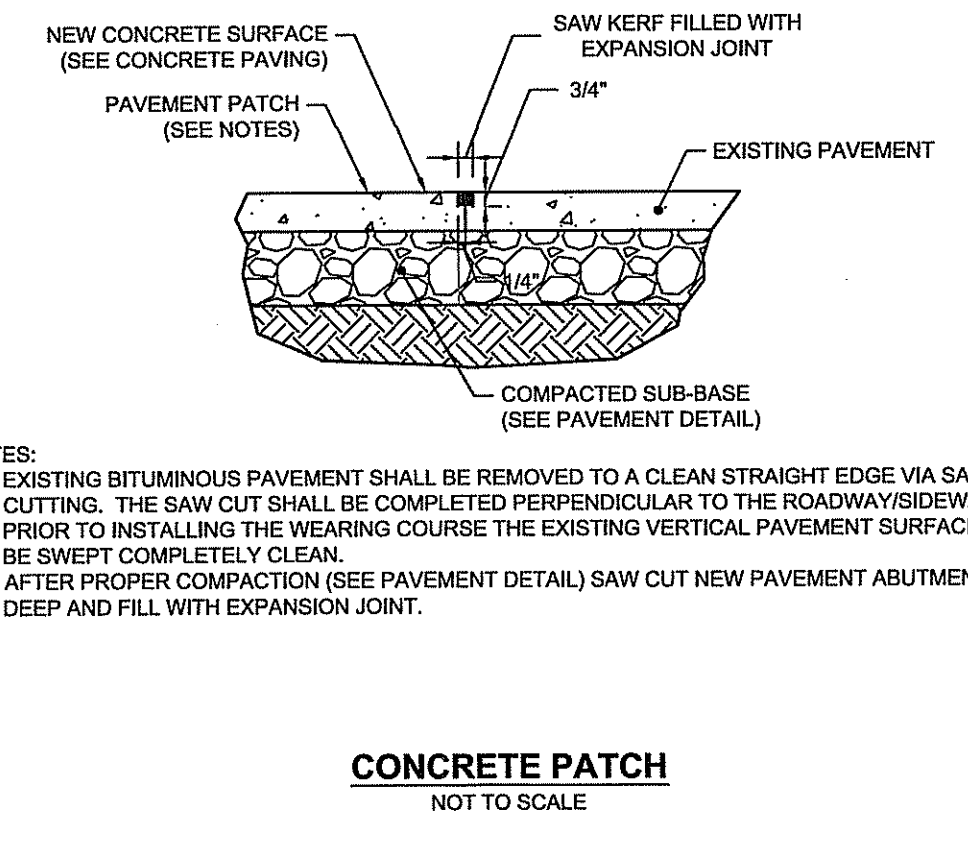

- NOTES:
1. EXISTING BITUMINOUS PAVEMENT SHALL BE REMOVED TO A CLEAN STRAIGHT EDGE VIA SAW CUTTING. THE SAW CUT SHALL BE COMPLETED PERPENDICULAR TO THE ROADWAY/SIDEWALK.
  2. PRIOR TO INSTALLING THE WEARING COURSE THE EXISTING VERTICAL PAVEMENT SURFACE SHALL BE SWEEPED COMPLETELY CLEAN.
  3. AFTER PROPER COMPACTION (SEE PAVEMENT DETAIL) SAW CUT NEW PAVEMENT ABUTMENT 3/4" DEEP AND FILL WITH EXPANSION JOINT.

- GENERAL NOTES:
1. DIMENSIONS MARKED WITH ( ) ARE REFERENCE DIMENSIONS. ACTUAL DIMENSIONS MAY VARY.
  2. WATER QUALITY STRUCTURE SHALL BE IN ACCORDANCE WITH ALL DESIGN DATA AND INFORMATION CONTAINED IN THIS DRAWING.
  3. STRUCTURE SHALL MEET AASHTO M30 AND CASTINGS SHALL MEET AASHTO M306 LOAD RATING, ASSUMING GROUNDWATER ELEVATION AT, OR BELOW, THE OUTLET PIPE INVERT ELEVATION. ENGINEER OF RECORD TO CONFIRM ACTUAL GROUNDWATER ELEVATION.

- INSTALLATION NOTES:
1. ANY SUB-BASE, BACKFILL DEPTH, AND/OR ANTI-FLOTATION PROVISIONS ARE SITE-SPECIFIC DESIGN CONSIDERATIONS AND SHALL BE SPECIFIED BY ENGINEER OF RECORD.
  2. CONTRACTOR TO PROVIDE EQUIPMENT WITH SUFFICIENT LIFTING AND REACH CAPACITY TO LIFT AND SET THE MANHOLE STRUCTURE (LIFTING CLUTCHES PROVIDED).
  3. CONTRACTOR TO INSTALL JOINT SEALANT BETWEEN ALL STRUCTURE SECTIONS AND ASSEMBLE STRUCTURE.
  4. CONTRACTOR TO PROVIDE, INSTALL, AND GROUT PIPES. MATCH PIPE INVERTS WITH ELEVATIONS SHOWN.
  5. CONTRACTOR TO TAKE APPROPRIATE MEASURES TO ASSURE UNIT IS WATER TIGHT, HOLDING WATER TO FLOWLINE INVERT MINIMUM. IT IS SUGGESTED THAT ALL JOINTS BELOW PIPE INVERTS ARE GROUTED.

SITE SPECIFIC DATA REQUIREMENTS			
STRUCTURE ID			
WATER QUALITY FLOW RATE (CFS)			
PEAK FLOW RATE (CFS)			
RETURN PERIOD OF PEAK FLOW (YRS)			
SCREEN APERTURE (200 OR 475)			
PIPE DATA:			
INLET PIPE 1	I.E.	MATERIAL	DIAMETER
INLET PIPE 2			
OUTLET PIPE			
RIM ELEVATION			
ANTI-FLOTATION BALLAST	WIDTH	HEIGHT	
NOTES/SPECIAL REQUIREMENTS:			
CONTRACTOR TO FIELD VERIFY INVERT AND RIM ELEV			
* PER ENGINEER OF RECORD			

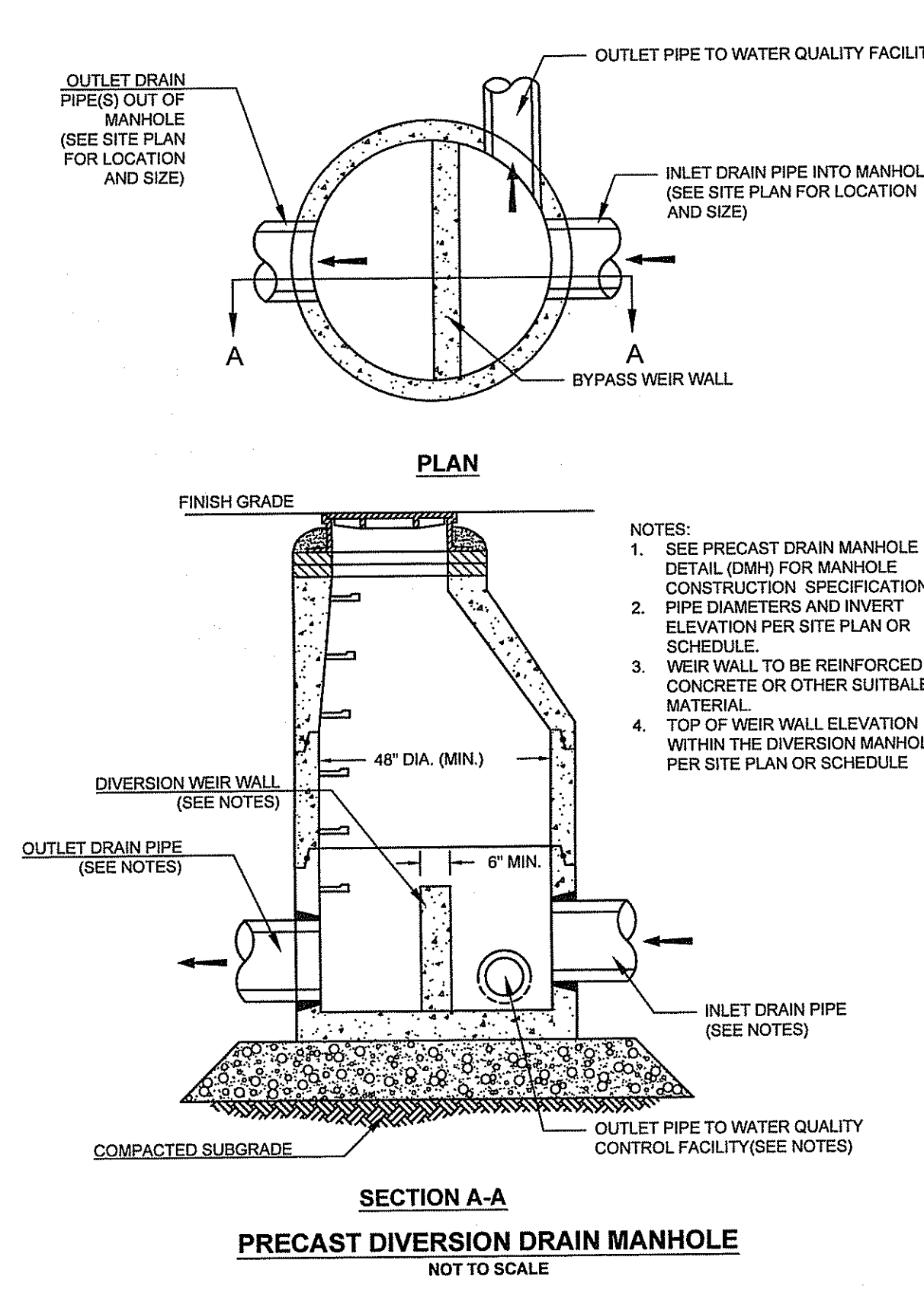

- NOTES:
1. SEE PRECAST DRAIN MANHOLE DETAIL (DMH) FOR MANHOLE CONSTRUCTION SPECIFICATION.
  2. PIPE DIAMETERS AND INVERT ELEVATION PER SITE PLAN OR SCHEDULE.
  3. WEIR WALL TO BE REINFORCED CONCRETE OR OTHER SUITABLE MATERIAL.
  4. TOP OF WEIR WALL ELEVATION WITHIN THE DIVERSION MANHOLE PER SITE PLAN OR SCHEDULE.

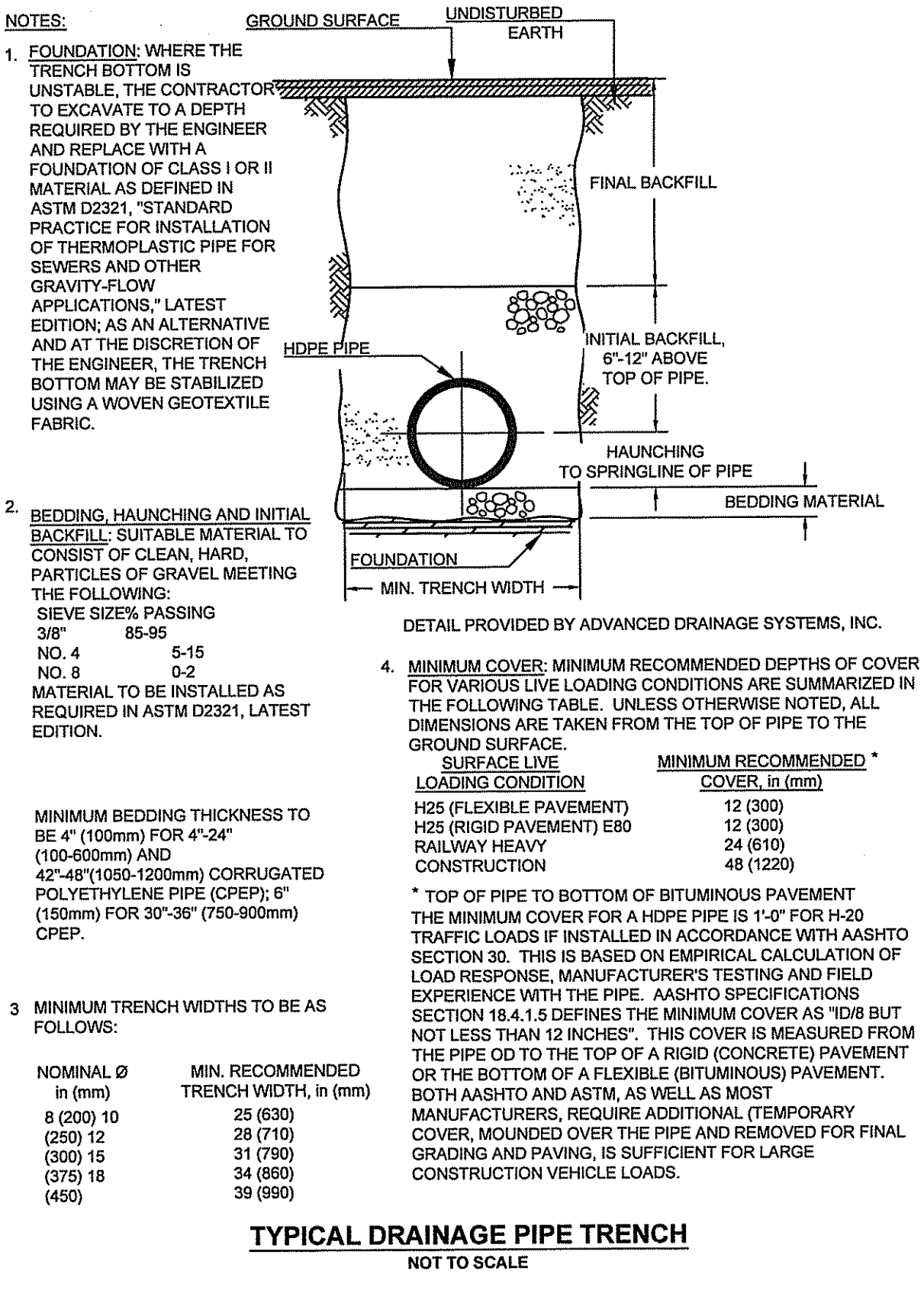

- NOTES:
1. FOUNDATION: WHERE THE TRENCH BOTTOM IS UNSTABLE, THE CONTRACTOR TO EXCAVATE TO A DEPTH REQUIRED BY THE ENGINEER AND REPLACE WITH A FOUNDATION OF CLASS I OR II MATERIAL AS DEFINED IN ASTM D2321. STANDARD PRACTICE FOR INSTALLATION OF THERMOPLASTIC PIPE FOR SEWERS AND OTHER GRAVITY-FLOW APPLICATIONS, LATEST EDITION, AS AN ALTERNATIVE AND AT THE DISCRETION OF THE ENGINEER, THE TRENCH BOTTOM MAY BE STABILIZED USING A WOVEN GEOTEXTILE FABRIC.
  2. BEDDING, HAUNCHING AND INITIAL BACKFILL: SUITABLE MATERIAL TO CONSIST OF CLEAN, HARD, PARTICLES OF GRAVEL MEETING THE FOLLOWING:
 

SIEVE SIZE*	PASSING
3/8"	85-95
NO. 4	5-15
NO. 8	0-2

 MATERIAL TO BE INSTALLED AS REQUIRED IN ASTM D2321, LATEST EDITION.
  3. MINIMUM TRENCH WIDTHS TO BE AS FOLLOWS:
 

NOMINAL Ø in (mm)	MIN. RECOMMENDED TRENCH WIDTH, in (mm)
8 (200)	10 (250)
12 (300)	15 (375)
15 (375)	18 (450)
18 (450)	25 (630)
24 (610)	31 (790)
30 (760)	37 (940)
36 (910)	43 (1090)
42 (1060)	49 (1240)
  4. MINIMUM COVER: MINIMUM RECOMMENDED DEPTHS OF COVER FOR VARIOUS LIVE LOADING CONDITIONS ARE SUMMARIZED IN THE FOLLOWING TABLE. UNLESS OTHERWISE NOTED, ALL DIMENSIONS ARE TAKEN FROM THE TOP OF PIPE TO THE GROUND SURFACE.
 

LOADING CONDITION	MINIMUM RECOMMENDED COVER, in (mm)
H25 (FLEXIBLE PAVEMENT)	12 (300)
H25 (RIGID PAVEMENT) E80	12 (300)
RAILWAY HEAVY CONSTRUCTION	24 (610)
CONSTRUCTION	48 (1220)

 \* TOP OF PIPE TO BOTTOM OF BITUMINOUS PAVEMENT THE MINIMUM COVER FOR A HDPE PIPE IS 1'-0" FOR H-20 TRAFFIC LOADS IF INSTALLED IN ACCORDANCE WITH AASHTO SECTION 30. THIS IS BASED ON EMPIRICAL CALCULATION OF LOAD RESPONSE, MANUFACTURER'S TESTING AND FIELD EXPERIENCE WITH THE PIPE. AASHTO SPECIFICATIONS SECTION 18.4.1.5 DEFINES THE MINIMUM COVER AS "10\"/>

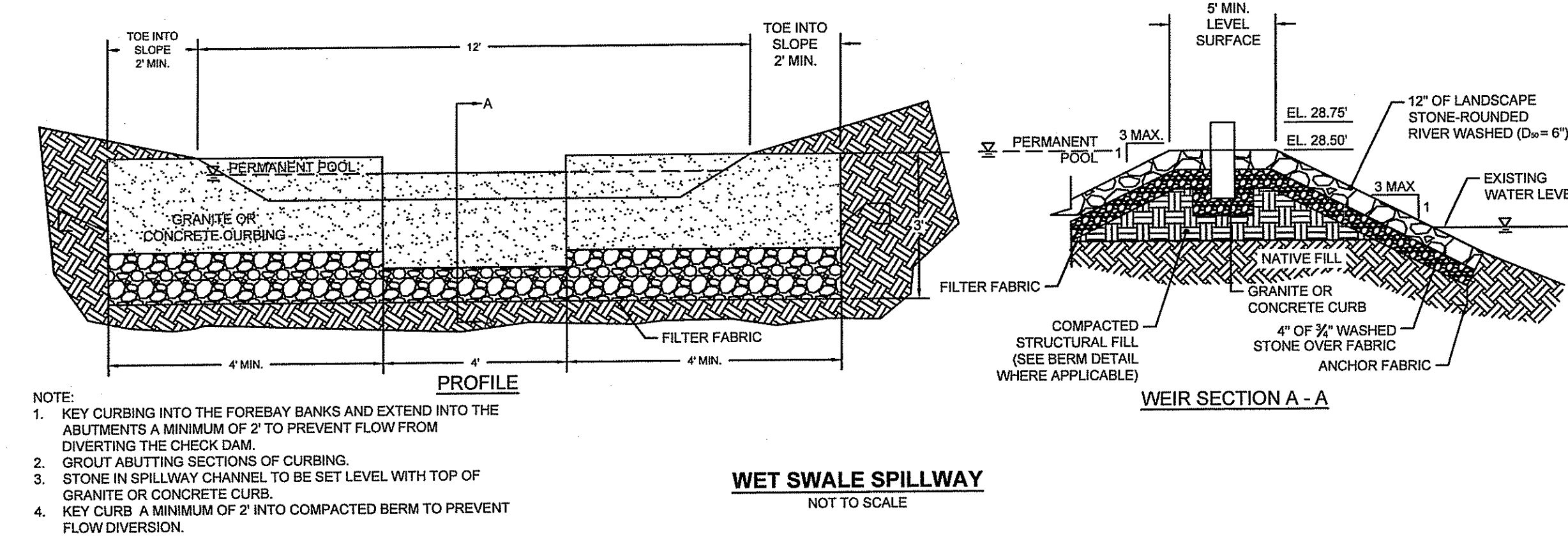
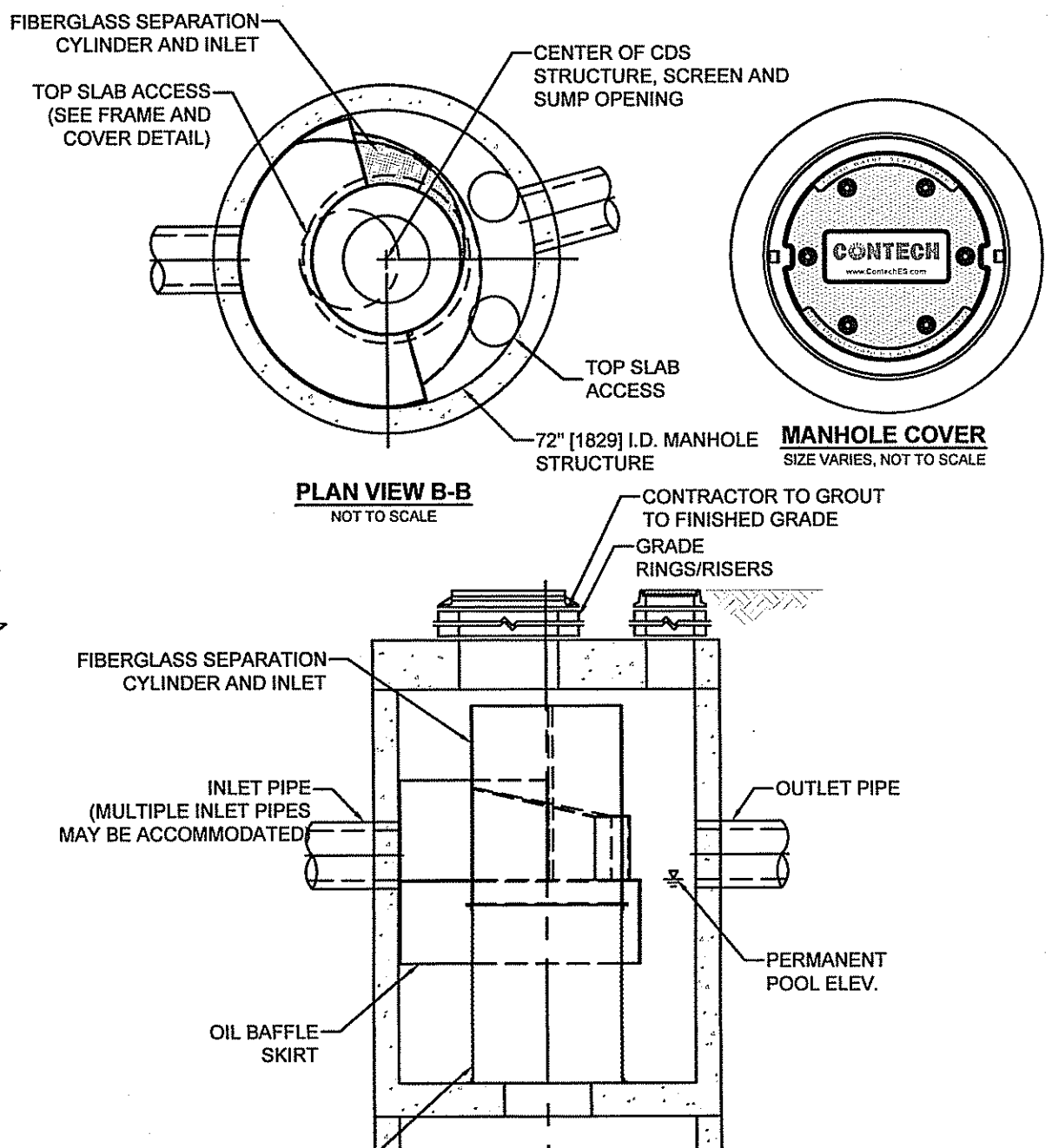
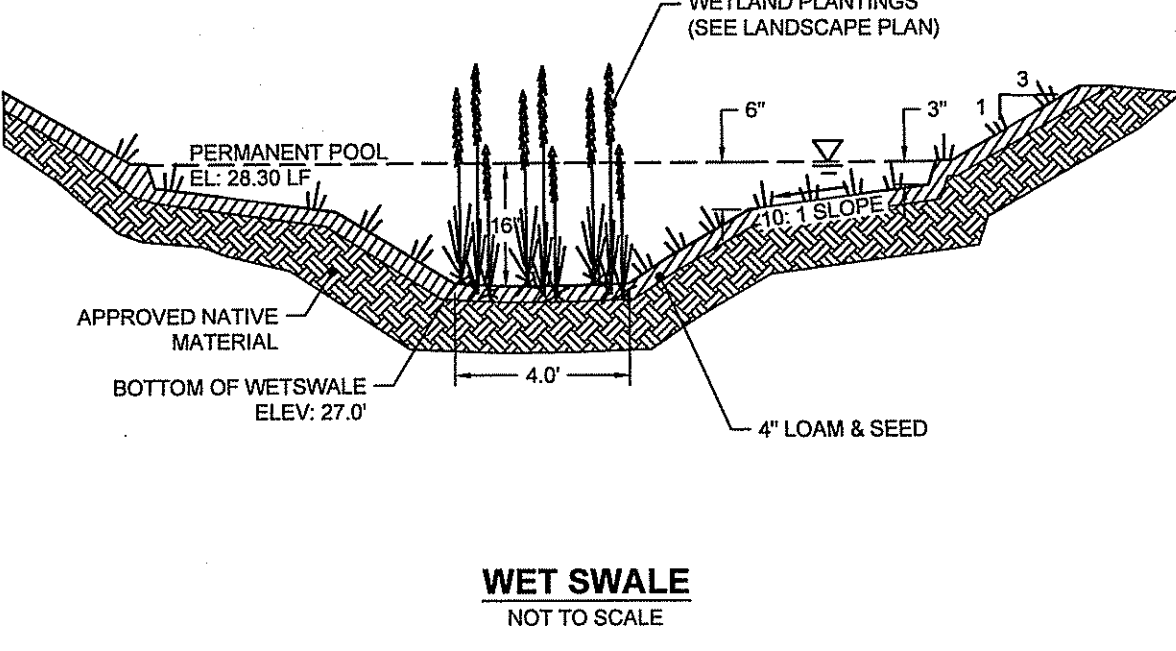
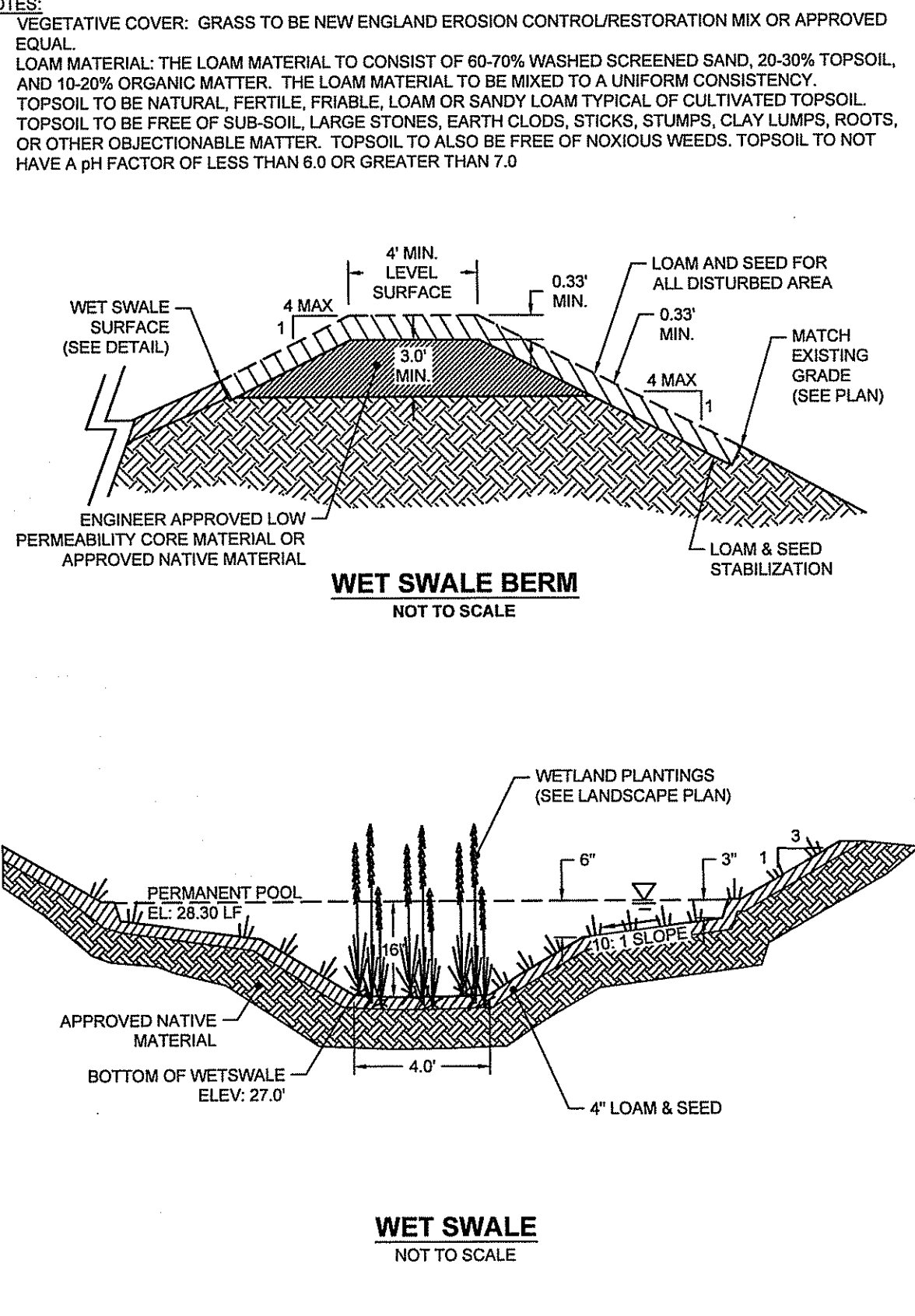

- NOTE:
1. KEY CURBING INTO THE FOREBAY BANKS AND EXTEND INTO THE ABUTMENTS A MINIMUM OF 2' TO PREVENT FLOW FROM DIVERTING THE CHECK DAM.
  2. GROUT ABUTTING SECTIONS OF CURBING.
  3. STONE IN SPILLWAY CHANNEL TO BE SET LEVEL WITH TOP OF GRANITE OR CONCRETE CURB.
  4. KEY CURB A MINIMUM OF 2' INTO COMPACTED BERM TO PREVENT FLOW DIVERSION.

DEPARTMENT OF ENVIRONMENTAL MANAGEMENT  
 OFFICE OF WATER RESOURCES  
 FRESHWATER WETLANDS PROGRAM  
 APPROVED WITH CONDITIONS  
 AS SPECIFIED IN THE LETTER OF APPROVAL  
 DATED DEC 19 2017 FILE # 17-0275  
 NO CHANGES ALLOWED WITHOUT THE SIGNATURE OF THE APPROVED PLANS MUST BE AT THE DEPARTMENT OF ENVIRONMENTAL MANAGEMENT

*James H. Hester*

NOV 16 2017  
 Office of Water Resources

PERMITTING SET ONLY  
 NOT FOR CONSTRUCTION

**BRYANT ASSOCIATES**  
 Sustainable Environmental Solutions  
 www.horsleywitten.com  
 90 Route 6A  
 Sandwich, MA 02563  
 508-833-6600 voice  
 508-833-3150 fax

**Horsley Witten Group, Inc.**  
 Sustainable Environmental Solutions  
 www.horsleywitten.com  
 90 Route 6A  
 Sandwich, MA 02563  
 508-833-6600 voice  
 508-833-3150 fax

**RI DOT**  
 RHODE ISLAND  
 DEPARTMENT OF TRANSPORTATION

**BRIAN F. KUCHAR**  
 PROFESSIONAL ENGINEER  
 CIVIL  
 11/13/17

DESIGNED BY:	GSG	SCALE:	N/A
CHECKED BY:	BRK		
DATE:	11/13/2017		
SHEET:	9		
OF:	11		

STORMWATER RETROFITS  
 ROGER WILLIAMS PARK-SITES 7A & 7B  
 CONTRACT: 00 VOLUME: 1  
 RHODE ISLAND

DETAILS (2)

Project: RWP-7A  
 Project Location: Roger Williams Park, Providence, RI  
 Calculated By: GSG  
 Checked By: BRK  
 Date: 10/5/2017

Project No: 16136A

Instructions: Enter values in cells only. All other cells are formulas or links and do not need to be edited. See cell comments for descriptions and formulas used.

**SITE 7A - SAND FILTER**  
 Water Quality Volume (WQv)

WQv (cf) = (1" rainfall/12) \* Imp. Area (sf)

#	Project	% Imp.	Drainage Area	Imp. Area	WQv Required*	WQv provided	WQv provided
		%	ac	ac	cf	cf	cf
RWP-7A	Sand Filter	37%	2.13	82.735	0.80	34.699	2.888
						1	43

**Surface Area (A1)**

Per Section 5.5.4 pgs 5-46 of the Manual, the minimum required filter bed area is computed using the following equation (City of Austin, 1988):

$A1 (sf) = WQv(d1) / [(K)(hf+d1)(t1)]$

Project RWP-28 - Sand Filter	
Water Quality Volume (WQv)	2888 cf
Filter Bed Depth (d1)	2.00 ft
Coefficient of permeability (K)	3.0 ft/day
height of water above filter	6 in
Average height of water (hf)	0.25 ft
Design Filter Drain Time (t1)	1.50 hrs
Surface Area Required	734 sqft
Surface Area Provided	1100 sqft
WQv Provided	4531 cf
Treatment Provided	157% WQv

**Minimum Forebay Area**

Per Section 6.4.1 pgs 6-7 and 6-8 of the Manual, the required surface area of the sediment chamber or forebay shall be determined using the following equation that is based on Camp-Hazen:

$A = 5750 * (WQv) / 66400$

Sediment Forebay (25% of the WQv)	
25% WQv	722 cf
depth	0.50 ft
Minimum Area Required (see formula above)	48 sqft
Length	42 ft
Width	16 ft
Length to Width ratio	2.58 ft
Surface Area Provided	1698 sqft
Volume Provided	849 cuft

Forebay Volume Provided 118%

Check 75% WQv	
75% WQv Required	2166 cf
Surface Ponding Volume	808 cf
Sediment Forebay Volume	362 cf
Filter Media Volume	726 cf
Total Filter Volume Provided	1894 cf
Extraction Volume	250 cf
Total Volume Provided	4420 cf

Notes:  
 \* Per Section 5.5 pg 5-41, the required percent of the water quality volume used for the sediment forebay for a sand filter is 25%.  
 \*\* The entire treatment system (including pretreatment) shall be sized to temporarily hold at least 75% of the WQv.

Figure 5-12 Sand Filter

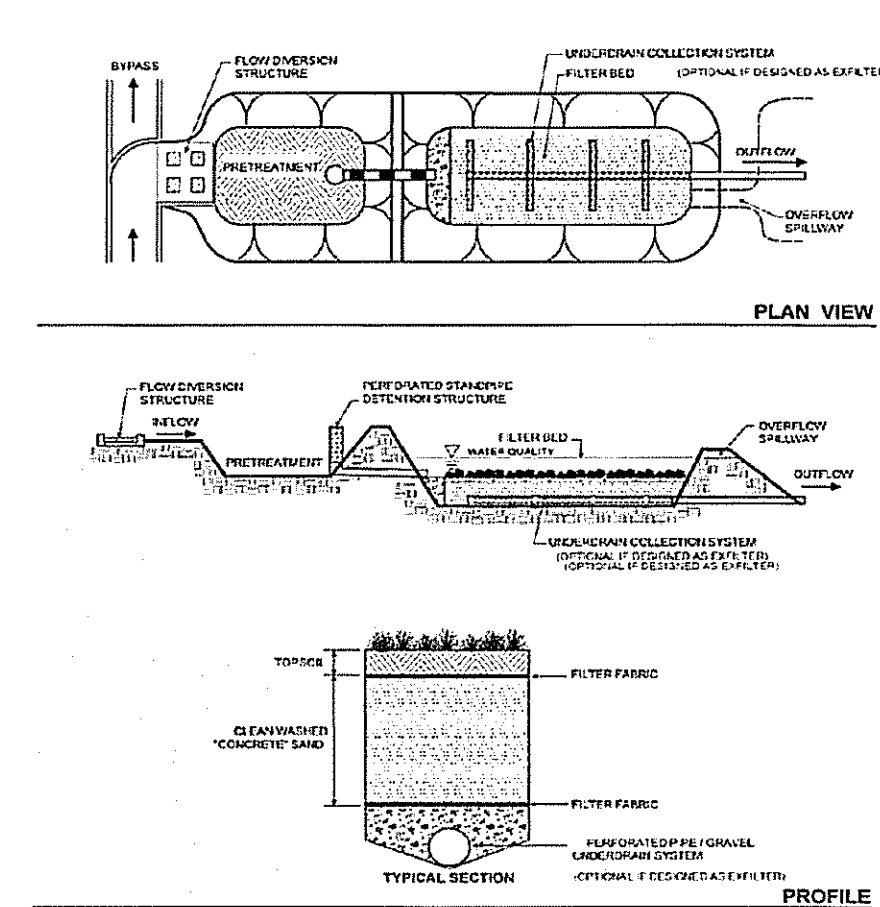

87%

Horsley Witten Group  
 www.horsleywitten.com

Project: RWP-7B  
 Project Location: Roger Williams Park, Providence, RI  
 Calculated By: GSG  
 Checked By: BRK  
 Date: 10/5/2017

Instructions: Enter values in cells only. All other cells are formulas or links and do not need to be edited. See cell comments for descriptions and formulas used.

**SITE 7B - WET SWALE**

Water Quality Volume (WQv)

WQv (cf) = (1" rainfall/12) \* Imp. Area (sf)

Project	Location	Drainage Area	Imp. Area	% Imp.	WQv	WQv	
		sf	sf	%	cf	ac-ft	
RWP-7B	Wet Swale	105,152	2,41	26,053	25%	2,171	0.050

**Dry Swale Sizing:**

Surface Area (A1)

$A1 (sf) = WQv(d1) / [(K)(hf+d1)(t1)]$

Project RWP-7B -	Wet Swale
Water Quality Volume (WQv)	2171 cf
Width of Swale Provided	VARIES
Length of Swale Provided	171 ft
Surface Area Provided	291 sqft
Bottom Elevation	27.00 ft
Permanent Pool Elevation	28.33 ft
Permanent Pool Depth	1.33 ft
Permanent Pool Volume	2518.00 cf
Water Quality Elevation	28.50 ft
Depth Above Permanent Pool	2.0 in
Volume Above Permanent Pool	563.00 cf
Water Quality Volume	3081.00 cf
Water Quality Volume	0.071 ac-ft

Percentage of Treatment Provided 142%

Sediment Forebay	
10% WQv required	217 cf
depth	0 ft
Surface Area Required	N/A sqft
Surface Area Provided	0 sf
Volume Provided	0 cf

Percentage of Treatment Provided 0% N/A

75% WQv STORAGE CHECK:			
Swale	Required 75% WQv (cf)	Ponded Volume (cf)	% of WQv Storage Provided
Wet Swale	1628	3081	189%

Figure 5-18 Wet Swale

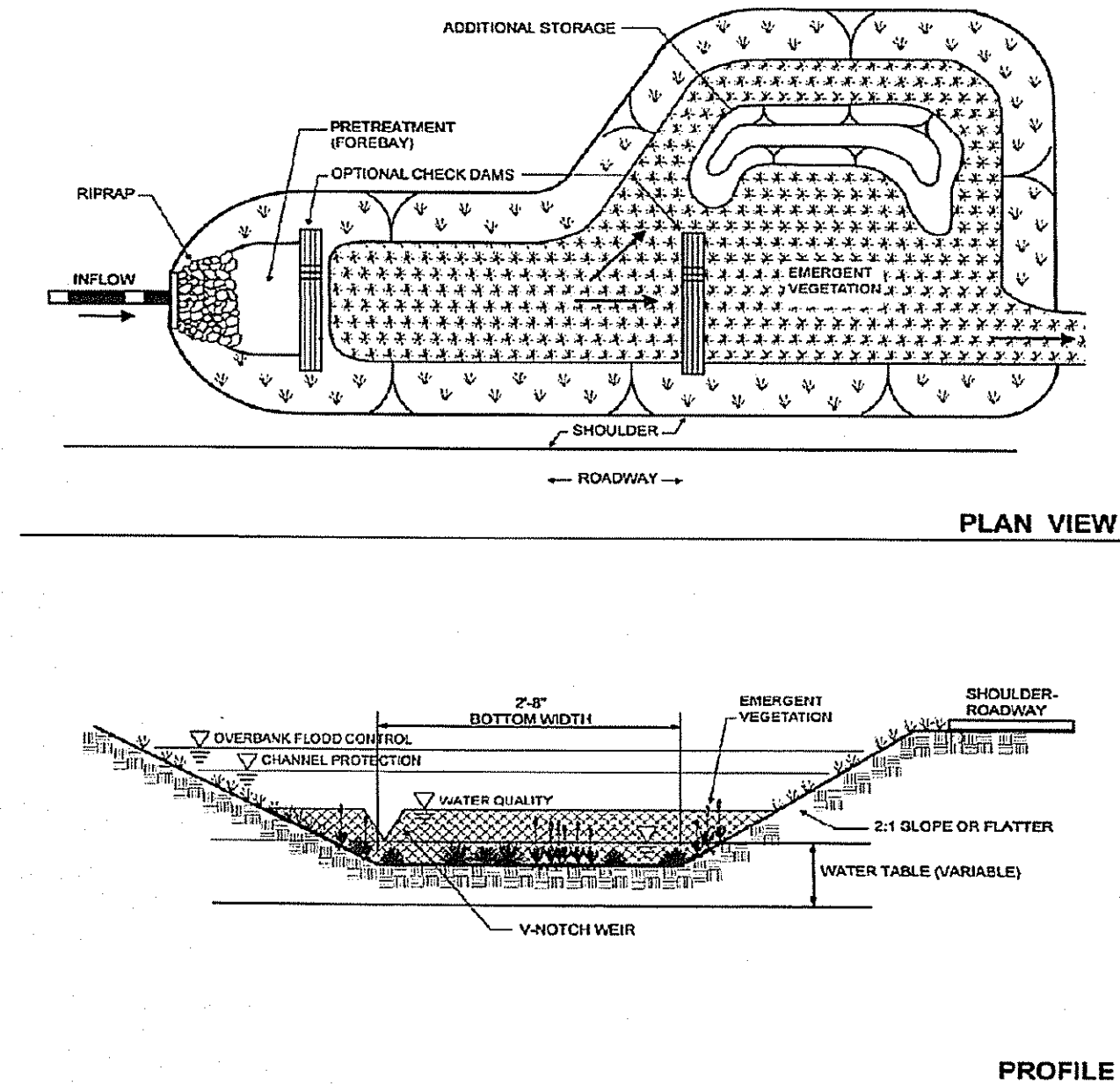

Hydrodynamic separator is provided.

DEPARTMENT OF ENVIRONMENTAL MANAGEMENT  
 OFFICE OF WATER RESOURCES  
 FRESHWATER WETLANDS PROGRAM  
 APPROVED WITH CONDITIONS  
 AS SPECIFIED IN THE LETTER OF APPROVAL  
 DATED DEC 17 2017 FILE # 17-0275  
 NO CHANGES ALLOWED WITHOUT PRIOR APPROVAL  
 APPROVED PLANS MUST BE AT CONSTRUCTION SITE

Charles H. Harkin

Environmental Management  
 NOV 16 2017

PERMITTING SET ONLY  
 NOT FOR CONSTRUCTION

**BRYANT ASSOCIATES**  
 Engineers Surveyors Construction Managers  
 640 George Washington Hwy, Bldg. C, Suite 100  
 Lincoln, Rhode Island 02865

**Horsley Witten Group, Inc.**  
 Sustainable Environmental Solutions  
 www.horsleywitten.com  
 90 Route 6A  
 Sandwich, MA 02563  
 508-833-6600 voice  
 508-833-3150 fax

**RI DOT** RHODE ISLAND  
 DEPARTMENT OF TRANSPORTATION

BRIAN R. KUCHAR  
 No. 10776  
 REGISTERED PROFESSIONAL ENGINEER (EIT)

DESIGNED BY: GSG  
 CHECKED BY: BRK  
 DATE: 11/13/2017  
 SHEET: 9  
 OF: 11

REVISIONS					
NO.	DATE	BY	NO.	DATE	BY

SCALE: N/A  
 STORMWATER RETROFITS  
 ROGER WILLIAMS PARK-SITES 7A & 7B  
 PROVIDENCE CONTRACT: 00 VOLUME: 1 RHODE ISLAND  
 SIZING CALCULATIONS

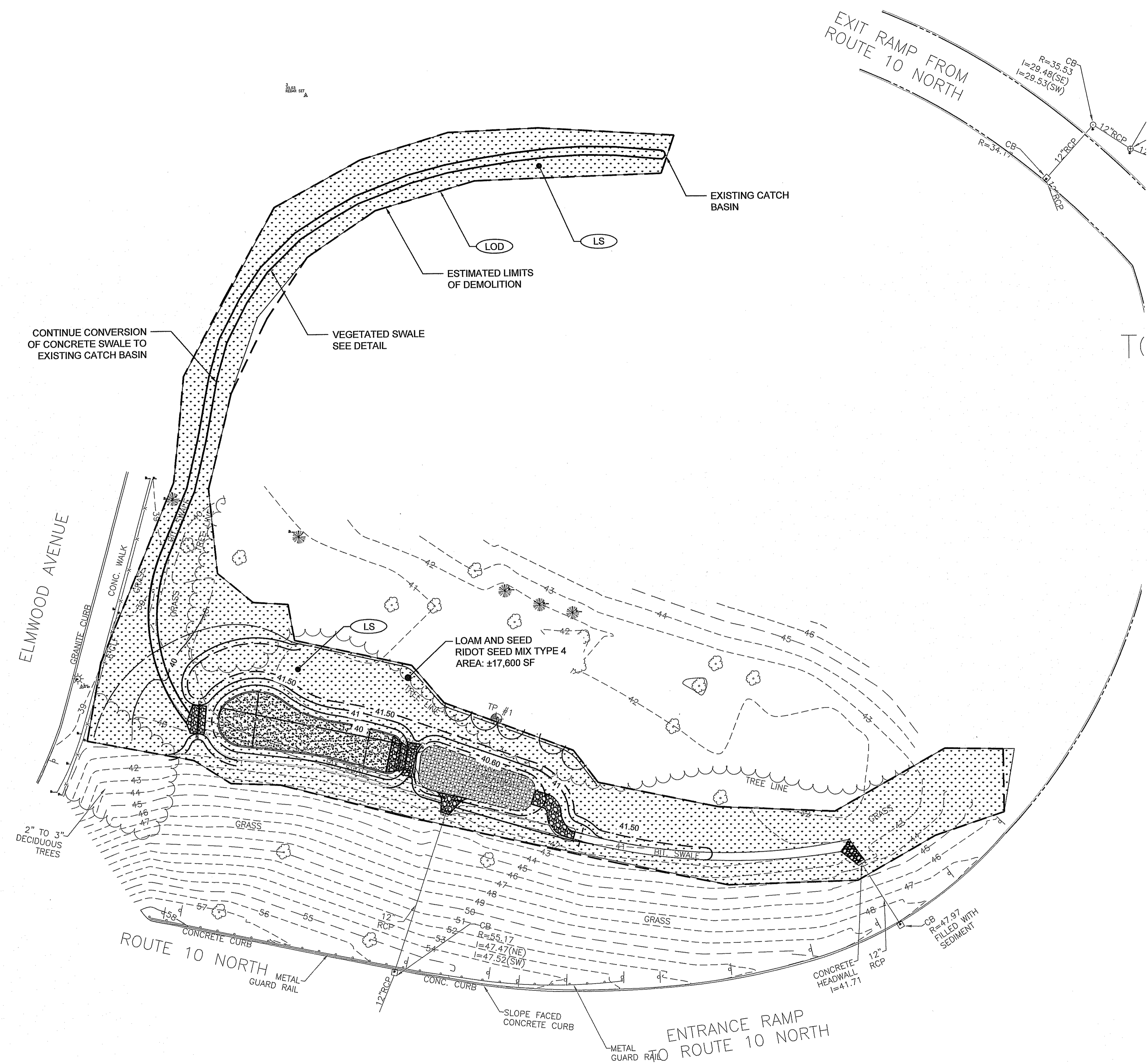

DEPARTMENT OF ENVIRONMENTAL MANAGEMENT  
 OFFICE OF WATER RESOURCES  
 FRESHWATER WETLANDS PROGRAM  
 APPROVED WITH CONDITIONS  
 AS SPECIFIED IN THE LETTER OF APPROVAL  
 DATED DEC 19 2017 FILE # 17-0275  
 NO CHANGES ALLOWED WITHOUT PRIOR APPROVAL  
 APPROVED PLANS MUST BE AT CONSTRUCTION

*Charles A. Herbert*

RIDOT SEED MIX TYPE 4  
 NATIVE SEED MIX OR APPROVED EQUIVALENT

Environmental Management  
 NOV 16 2017  
 Office of Water Resources

PERMITTING SET ONLY  
 NOT FOR CONSTRUCTION

**BRYANT ASSOCIATES**  
 Engineers Surveyors Construction Managers  
 840 George Washington Hwy. Bldg. C, Suite 100  
 Lincoln, Rhode Island 02865

**Horsley Witten Group, Inc.**  
 Sustainable Environmental Solutions  
 www.horsleywitten.com  
 90 Route 6A  
 Sandwich, MA 02563  
 508-833-6600 voice  
 508-833-3150 fax

**RI DOT** RHODE ISLAND DEPARTMENT OF TRANSPORTATION

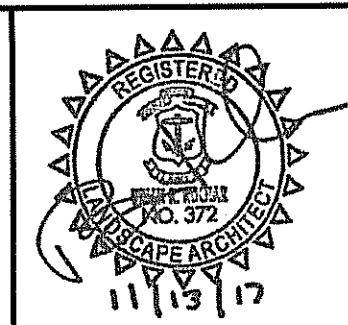

DESIGNED BY: PK  
 CHECKED BY: BRK  
 DATE: 11/13/2017  
 SHEET: 10  
 OF: 11

SCALE: 1"=20'

REVISIONS			REVISIONS		
NO.	DATE	BY	NO.	DATE	BY

STORMWATER RETROFITS  
 ROGER WILLIAMS PARK-SITES 7A & 7B  
 PROVIDENCE CONTRACT: 00 VOLUME: 1 RHODE ISLAND  
**SITE 7A - LANDSCAPE PLAN**

**LANDSCAPE NOTES:**

- ALL PLANT MATERIAL MUST BE TAGGED AT THE NURSERY (A RECOGNIZED GROWER OF PLANT MATERIAL) IN ACCORDANCE WITH THE R.I.D.O.T. STANDARD SPECIFICATIONS, LATEST EDITION. ALL PLANT MATERIAL MUST BE NURSERY GROWN; NO PLANTATION GROWN PLANT MATERIAL WILL BE ACCEPTED.
- ALL PLANT SUBSTITUTIONS AND/OR CHANGES IN PLANT LOCATION MUST BE APPROVED IN ACCORDANCE WITH THE R.I.D.O.T. STANDARD SPECIFICATIONS, LATEST EDITION.
- ALL PLANT MATERIAL IS TO BE FIELD LOCATED BY A REPRESENTATIVE FROM THE R.I.D.O.T. LANDSCAPE ARCHITECTURE UNIT.
- A R.I.D.O.T. LANDSCAPE REPRESENTATIVE MUST BE ON SITE TO APPROVE ALL TRIMMING AND CLEARING NECESSARY TO COMPLETE THE WORK AS SHOWN ON THE PLANS.
- ANY TOPSOIL USED AS PLANTABLE SOIL SHALL HAVE A SANDY LOAM TEXTURE RELATIVELY FREE OF SUBSOIL MATERIAL, STONES, ROOTS, LUMPS OF SOIL, TREE LIMBS, TRASH OR CONSTRUCTION DEBRIS, AND SHALL CONFORM TO SECTION M.18 OF THE R.I.D.O.T. STANDARD SPECIFICATIONS, LATEST EDITION.
- ALL TREES AND SHRUBS SHALL BE MULCHED WITH PINE BARK MULCH IN ACCORDANCE WITH THE R.I.D.O.T. STANDARD SPECIFICATIONS, LATEST EDITION.
- ALL TREES AND/OR SHRUBS THAT ARE PLANTED AS A BED SHALL BE MULCHED AS A BED.
- PROVIDE A MINIMUM 6"-8" BRANCHING STANDARD ON ALL TREES INSTALLED ADJACENT TO SIDEWALKS AND/OR PEDESTRIAN ACCESS AREAS.

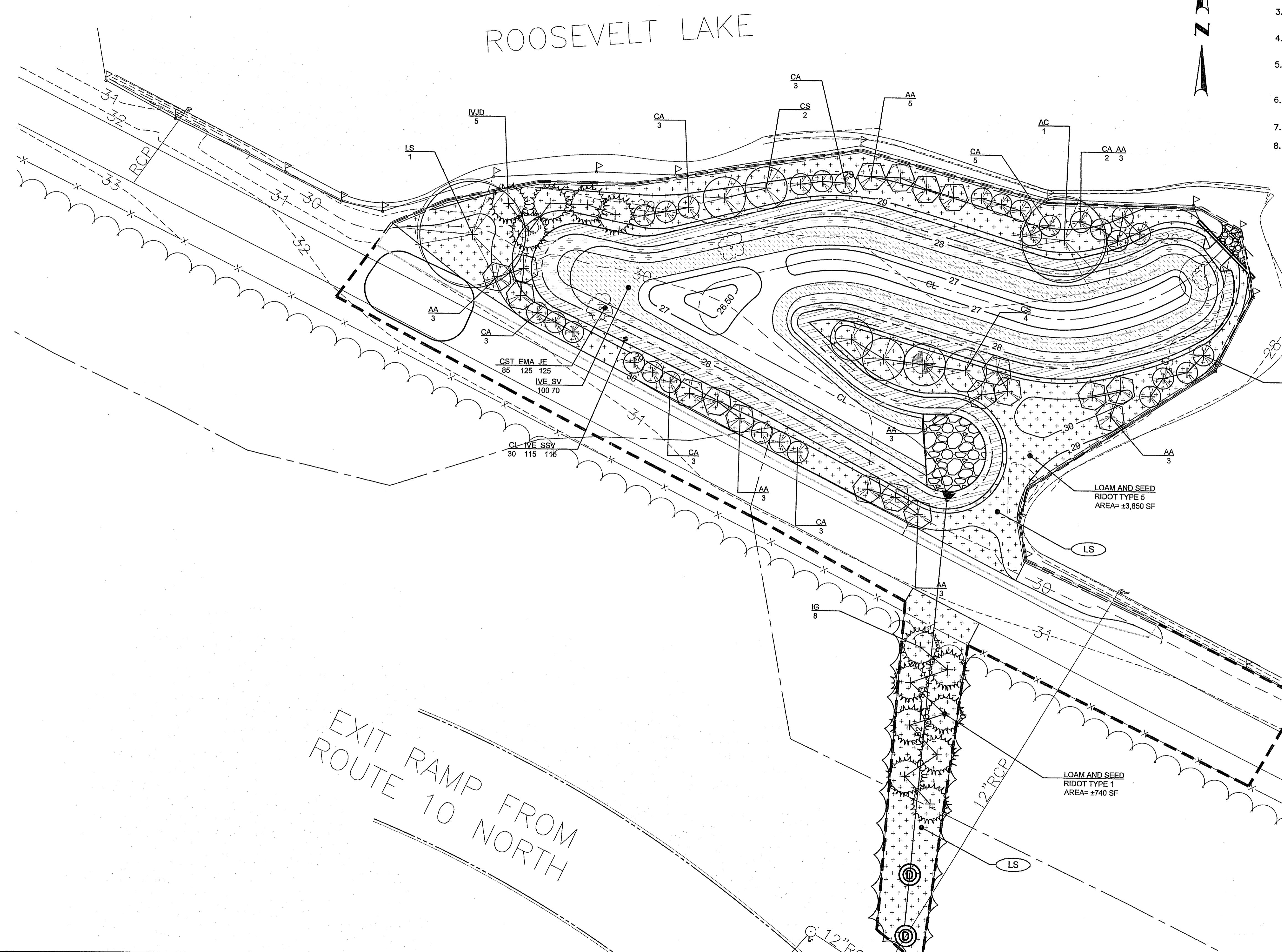

**Sites 7B Plant List**

Key	Botanical Name	Common Name	Size	Spacing
<b>Trees</b>				
AC 1	<i>Amelanchier canadensis</i>	Shadblow Juneberry	5/6" B&B	As Shown
LS 1	<i>Liquidambar styraciflua</i>	Sweet Gum	1.5" - 2" CAL	As Shown
<b>Shrubs</b>				
AA 20	<i>Aronia melanocarpa</i> 'Morton'	Morton Black Chokeberry	#3	3.5' O.C.
CA 26	<i>Clethra alnifolia</i>	White Summer Sweet	#3	5' O.C.
CSAF 6	<i>Cornus sericea</i> 'Arctic Fire'	Arctic Fire Red Twig Dogwood	#3	3.5' O.C.
IG 8	<i>Ilex glabra</i>	Inkberry	#5	As Shown
IVJD 5	<i>Ilex verticillata</i> 'Jim Dandy'	Jim Dandy Winterberry	#3	4' O.C.
<b>Ground Cover/Grasses/Perennials</b>				
CST 85	<i>Carex stricta</i>	Tussock Sedge	plugs	24" O.C.
CL 30	<i>Chasmanthium latifolium</i>	Indian Woodoats	plugs	3' O.C.
EMA 125	<i>Eupatorium maculatum</i>	Joe-Pye Weed	plugs	18" O.C.
IVE 215	<i>Iris versicolor</i>	Blue Flag	plugs	18" O.C.
JE 125	<i>Juncus effusus</i>	Soft Rush	plugs	18" O.C.
SV 70	<i>Scirpus validus</i>	Soft-stemmed Bulrush	plugs	30" O.C.
SSV 115	<i>Solidago virgaurea</i>	Golden rod	plugs	18" O.C.

NOTE: SEE RIDOT STANDARD DETAIL 50.3.2 FOR ALL SHRUBS PLANTED ON SLOPE

**RIDOT SEED MIX TYPE 5**  
NEW ENGLAND WETMIX OR APPROVED EQUIVALENT

- CAREX VULPINOIDEA (FOX SEDGE)
- CAREX SCOPARIA (BLUNT BROOM SEDGE)
- VERBENA HASTATA (BLUE VERVAIN)
- CAREX LURIDA (LURID SEDGE)
- POA PALUSTRIS (POWL BLUEGRASS)
- BIDENS ARISTOSA (TICKSEED SUNFLOWER/BUR MARIGOLD)
- CAREX LUPULINA (HOP SEDGE)
- SCIRPUS ATROVIRENS (GREEN BULRUSH)
- ELEOCHARIS PALUSTRIS (CREEPING SPIKE RUSH)
- JUNCUS EFFUSUS (SOFT RUSH)
- CAREX CRINITA (FRINGE SEDGE)
- ASCLEPIAS INCARNATA (SWAMP MILKWEED)
- ASTER PUNICEUS (SWAMP ASTER)
- GLYCERIA CANADENSIS (RATTLESNAKE GRASS)
- MIMULUS RINGENS (SQUARE STEMMED MONKEY FLOWER)
- EUPATORIUM MACULATUM (SPOTTED JOE PYE WEED)
- IRIS VERSICOLOR (BLUE FLAG)

**RIDOT SEED MIX TYPE 4**  
NATIVE SEED MIX OR APPROVED EQUIVALENT

DEPARTMENT OF ENVIRONMENTAL MANAGEMENT  
OFFICE OF WATER RESOURCES  
FRESHWATER WETLANDS PROGRAM  
APPROVED WITH CONDITIONS  
AS SPECIFIED IN THE LETTER OF APPROVAL  
DATED DEC 19 2017 FILE # 17-0275  
NO CHANGES ALLOWED WITHOUT PRIOR APPROVAL  
APPROVED PLAN AND SET BY: [Signature]

[Signature]  
NOV 16 2017  
Office of Water Resources

**PERMITTING SET ONLY  
NOT FOR CONSTRUCTION**

**BRYANT ASSOCIATES**  
Engineers Surveyors Construction Managers  
840 George Washington Hwy, Bldg. C, Suite 100  
Lincoln, Rhode Island 02865

**Horsley Witten Group, Inc.**  
Sustainable Environmental Solutions  
www.horsleywitten.com  
90 Route 6A  
Sandwich, MA 02563  
508-833-6600 voice  
508-833-3150 fax

**RIDOT** RHODE ISLAND DEPARTMENT OF TRANSPORTATION

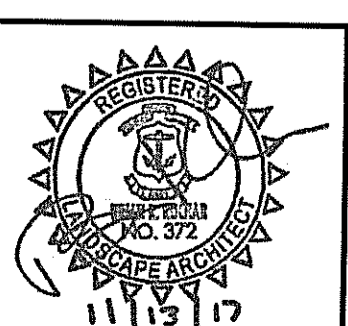

DESIGNED BY: PK  
CHECKED BY: BRK  
DATE: 11/13/17  
SHEET: 11  
OF: 11

SCALE: 1"=10'

REVISIONS			REVISIONS		
NO.	DATE	BY	NO.	DATE	BY

STORMWATER RETROFITS  
ROGER WILLIAMS PARK-SITES 7A & 7B  
PROVIDENCE CONTRACT: 00 VOLUME:1 RHODE ISLAND  
**SITE 7B - LANDSCAPE PLAN**