

ZONING DISTRICT: F2  
 MINIMUM SETBACKS: FRONT - 40'  
 REAR - 40'  
 SIDE - 15'

**LOCUS MAP**  
 SCALE: 1" = 80'

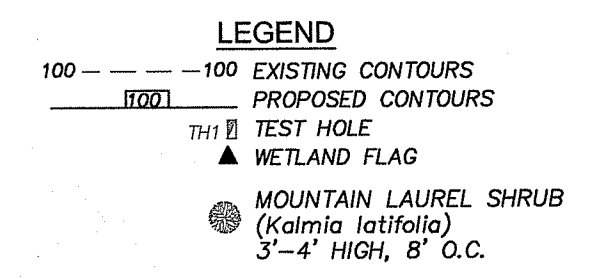

**LOCUS MAP**  
 NOT TO SCALE

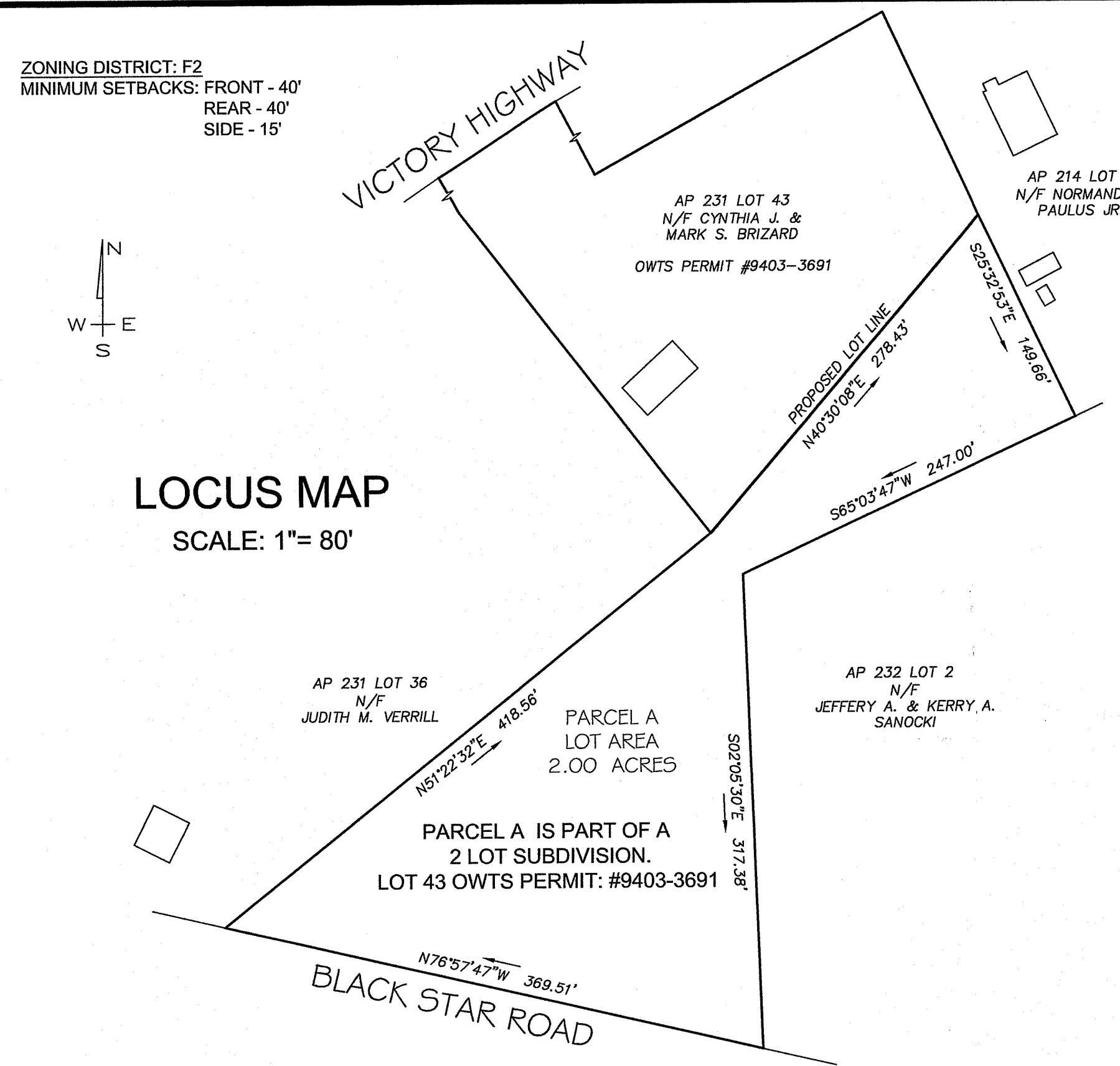
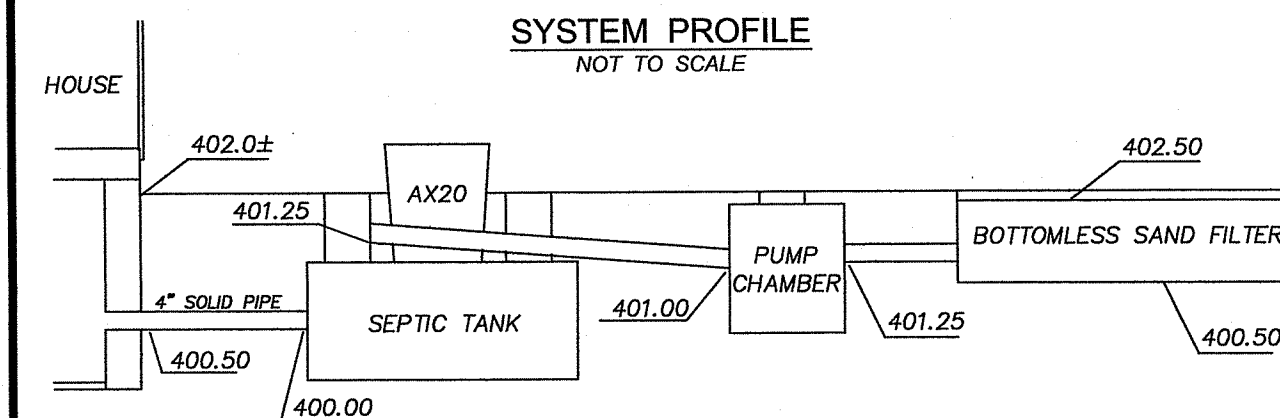
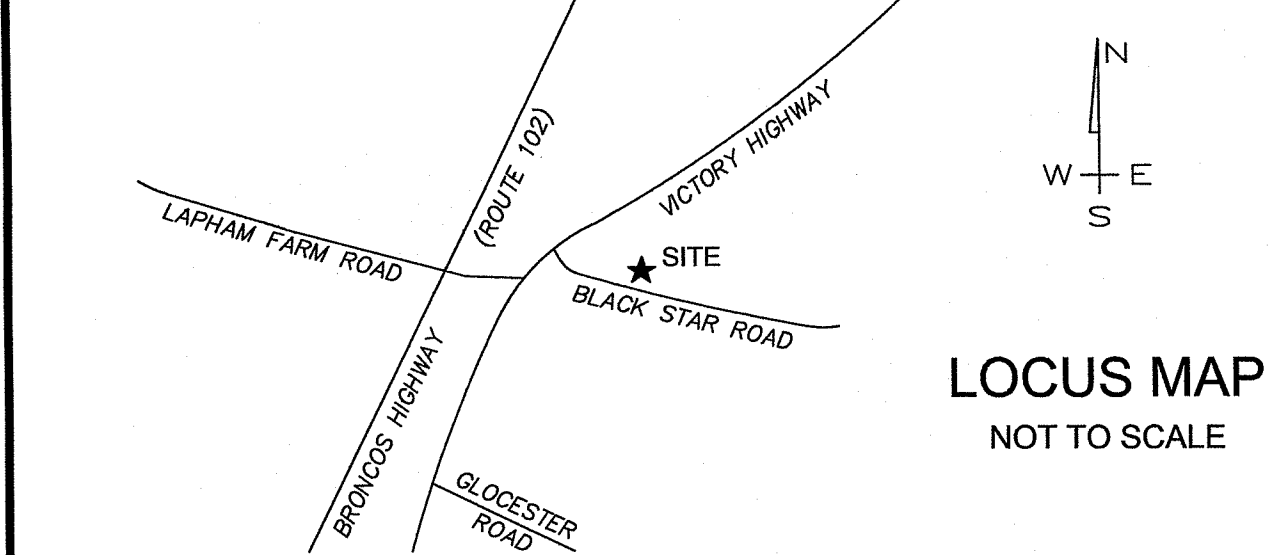

- NOTES**
- 1) SYSTEM INSTALLATION TO BE SUPERVISED BY THE DESIGNER.
  - 2) ALL TREES AND/OR STUMPS WITHIN 100 FEET OF PROPOSED SYSTEM TO BE CLEARED.
  - 3) NO WELL EXISTS WITHIN 100' OF THE PROPOSED LEACHING SYSTEM.
  - 4) 5 FEET FROM SAND FILTER NOT TO BE LOWER THAN ELEVATION 400.50.
  - 5) ANY PRIVATE WELLS, EXISTING & PROPOSED, WITHIN 200' OF DWTS ARE SHOWN.
  - 6) ANY PUBLIC WELLS, EXISTING AND PROPOSED, WITHIN 500' OF DWTS ARE SHOWN.
  - 7) SEPTIC TANK TO BE A MINIMUM OF 75' FROM ALL WELLS.
  - 8) NO DRAINS OF ANY KIND SHALL BE WITHIN 25' UPGRADIENT OR 50' DOWNGRADIENT OF THE LEACHING SYSTEM.
  - 9) ALL SOIL AT LEAST 6" BELOW EXISTING GRADE AT BOTTOMLESS SAND FILTER SHALL BE STRIPPED AND BACKFILLED WITH FILTER SAND.
  - 10) THE SEPTIC TANK SHALL BE A WATER-TIGHT, 1,500 GALLON 2-COMPARTMENT TANK WITH 24" DIAMETER INLET AND OUTLET ACCESS RISERS. RISERS SHALL BE PVC WITH SECURE FIBERGLASS LIDS. IF CONCRETE TANK IS USED, ASB TANK ADAPTER SHALL BE CAST IN PLACE. TANK SHALL BE VACUUM TESTED WHEN CONSTRUCTED (W/CERTIFICATE) OR WATER TESTED/VACUUM TESTED ON SITE PRIOR TO ACCEPTANCE FROM THE ENGINEER.
  - 11) THE ADVANTEX-AX TREATMENT SYSTEM CONTAINS A PACKED BED FILTER THAT USES SPECIALLY DESIGNED TEXTILE MATERIALS WITHIN A PRE-ASSEMBLED FILTER UNIT.
  - 12) ALL PUMPS SHALL BE EQUIPPED WITH A HIGH WATER LEVEL VISABLE AND AUDIBLE ALARM POWERED BY A CIRCUIT SEPARATE FROM THE PUMP POWER. THE ALARM SHALL BE LOCATED IN A NORMALLY OCCUPIED AREA OF THE DWELLING OR SHALL BE INSTALLED AT A LOCATION TO BE DESIGNATED BY THE HOMEOWNER.
  - 13) THE SEPTIC TANK SHALL BE PROVIDED WITH A PVC INLET TEE AND SCREENING PUMP VAULT IN THE OUTLET END. AN ACCESS RISER SHALL BE INSTALLED DIRECTLY ABOVE THE SCREENED PUMP VAULT AND INLET TEE.
  - 14) ALL MEDIA WITHIN THE ENCLOSURE AND BELOW THE COVER STONE SHALL HAVE AN EFFECTIVE SIZE (D<sub>10</sub>) OF 0.33 mm (+/-) AND UNIFORMITY COEFFICIENT (U<sub>60</sub>) OF 3.0 TO 4.0. THE MAXIMUM ALLOWABLE PERCENTAGE OF FINES PASSING THROUGH A NUMBER 200 SIEVE SHALL BE OTHER THAN THE GRADATION AND FINE CONTENT SPECIFIED ABOVE. THE SAND MEDIA SHALL MEET OTHER ASTM C-33 SAND SPECIFICATIONS.
  - 15) IF CONTRACTOR ENCOUNTERS ANY CONDITIONS DURING CONSTRUCTION WHICH INDICATE THE SYSTEM CANNOT BE INSTALLED IN ACCORDANCE WITH THE APPROVED DESIGN, OR FIND CONFLICTING INFORMATION ON THE PLAN, CONSTRUCTION SHALL CEASE AND DESIGNER BE NOTIFIED.
  - 16) THE DESIGNER IS NOT RESPONSIBLE FOR ANY NEGLIGENT ACT OF OMISSION OF AN ISDS USER, INCLUDING BUT NOT LIMITED TO, FAILURE TO PROPERLY USE AND MAINTAIN THE SYSTEM, WHICH CAUSES DAMAGE TO THE SYSTEM.
  - 17) NO STRUCTURES, PERMANENT FEATURES, OR LARGE, HEAVY OR NUMEROUS DECORATIONS SHALL BE PLACED ON TOP OF THE BOTTOMLESS SAND FILTER THAT WOULD OBSTRUCT, PREVENT OR HINDER OPERATION AND MAINTENANCE OR ACCESS TO THE BSF.
  - 18) ACCESS PORTS OR MANHOLES SHALL BE REQUIRED FOR SEQUENCING VALVES AND SHALL BE SUFFICIENTLY SIZED TO FACILITATE MAINTENANCE.
  - 19) TIMER SETTINGS SHALL BE CHECKED AT EVERY ESTABLISHED MAINTENANCE AND INSPECTION VISIT AND WHEN HOME OCCUPANCY CHANGES AND ADJUSTED AS NEEDED.
  - 20) THE PANEL BOX MUST BE WITHIN VIEW OF THE SYSTEM LOCATION TO HELP FACILITATE OPERATION AND MAINTENANCE.
  - 21) THE SPACE FROM THE ENDS OF THE LATERALS TO THE LINER SHALL BE CLOSE TO HALF THE ORIFICE SPACING AND BE ABLE TO ACCOMMODATE THE FITTINGS AND HAVE SUFFICIENT SPACE FOR MAINTENANCE ACTIVITIES.
  - 22) SWEEP ELBOWS SHALL BE ATTACHED TO THE DISTAL END OF EACH LATERAL TO FACILITATE MAINTENANCE AND INSPECTION.
  - 23) REFER TO OPERATION & MAINTENANCE AGREEMENT FOR PROPER MAINTENANCE OF ALL SYSTEM COMPONENTS.

**SYSTEM SIZING:**

4 BEDROOMS: 115 GPD x 4 = 460 GPD  
 SOIL CATEGORY: 6  
 APPLICATION RATE: 2.3 GPD/SF  
 AREA REQUIRED: 460/2.3 = 200 SF  
 AREA PROVIDED: 10' x 20' = 200 SF

**DOSING RATE:**

19.16 GAL/DOSE  
 PUMP CHAMBER CAPACITY = 23.5 GAL/FT OR 1.96 GAL./INCH  
 PUMP CHAMBER DEPTH @ 19.16 GAL = 81 FEET  
 DOSE PER ORIFICE = 460 GPD/(24 DOSES/DAY)/84 ORIFICES = .23 GAL./ORIFICE/DOSE

**TIMER INFO:**

SET ADVANTEX TIMER TO 24 DOSES/DAY  
 460 GPD/24 DOSES/DAY = 19.16 GAL/DOSE  
 19.16 GAL/DOSE = .56 MIN.  
 TOTAL PUMP RUN TIME = 13.44 MIN./DAY  
 TOTAL PUMP OFF TIME = 1426.56 MIN./DAY  
 TIME OFF PER CYCLE = 59.44 MIN.  
 TIME ON PER CYCLE = 0.56 MIN.

**ENVIRONMENTAL MANAGEMENT**  
 9403-2052 RWMA 21-0318  
 APPROVED: [Signature] DATE: 1/23/22  
 No Changes Allowed Without RIDEM Approval  
 Approved Plans/Permit Must be Kept at Construction Site

**PROPOSED ONSITE WASTEWATER TREATMENT SYSTEM & WETLANDS PLAN**  
 for  
**PLAT 231, PART OF LOT 43, PARCEL A**  
**BLACK STAR ROAD**  
**BURRILLVILLE, RHODE ISLAND**  
**NOVEMBER, 2021**  
**REVISED: 1-4-22**  
**SCALE 1" = 20'**

THIS SURVEY HAS BEEN CONDUCTED AND THE PLAN HAS BEEN PREPARED PURSUANT TO SECTION 9 OF THE RULES AND REGULATIONS ADOPTED BY THE RHODE ISLAND STATE BOARD OF REGISTRATION FOR PROFESSIONAL LAND SURVEYORS ON NOVEMBER 25, 2015, AS FOLLOWS:  
 - LIMITED CONTENT BOUNDARY SURVEY: CLASS IV  
 - TOPOGRAPHIC ACCURACY: 1-4  
 Marc N. Nyberg  
 MARC N. NYBERG LICENSE No. 1797 COA No. A52  
 STATEMENT OF PURPOSE  
 THE PURPOSE FOR THE CONDUCT OF THE SURVEY AND THE PREPARATION OF THE PLAN IS AS FOLLOWS: PROPOSED HOUSE

MARC N. NYBERG  
 No. 1797  
 PROFESSIONAL LAND SURVEYOR

**AN SITE** Engineering Services, LLC  
 PROFESSIONAL ENGINEERS | LAND SURVEYORS  
 Precision. Clarity. Certainty.  
 501 Great Road, Unit 104  
 North Smithfield, Rhode Island 02896  
 Phone: (401) 762-2870 Fax: (401) 401-762-2871  
 Web Address: [nlsengineers.com](http://nlsengineers.com)

**RAIN GARDEN PLANTING DETAIL**  
 NOT TO SCALE

- RAIN GARDEN A ROOF AREA: 728 SF  
 SOIL TEXTURE: SANDY LOAMS  
 AREA: 64 SF  
 16 PLANTS
- RAIN GARDEN B ROOF AREA: 1350 SF  
 SOIL TEXTURE: SANDY LOAMS  
 AREA: 112 SF  
 28 PLANTS
- Orange Coneflower
  - Mountain Laurel
  - Blue Flag Iris
  - Butterfly Milkweed

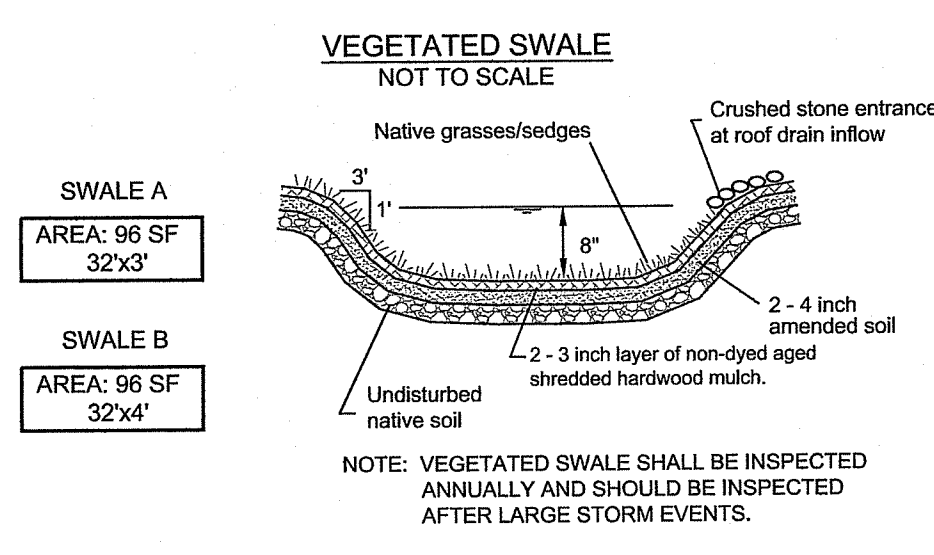
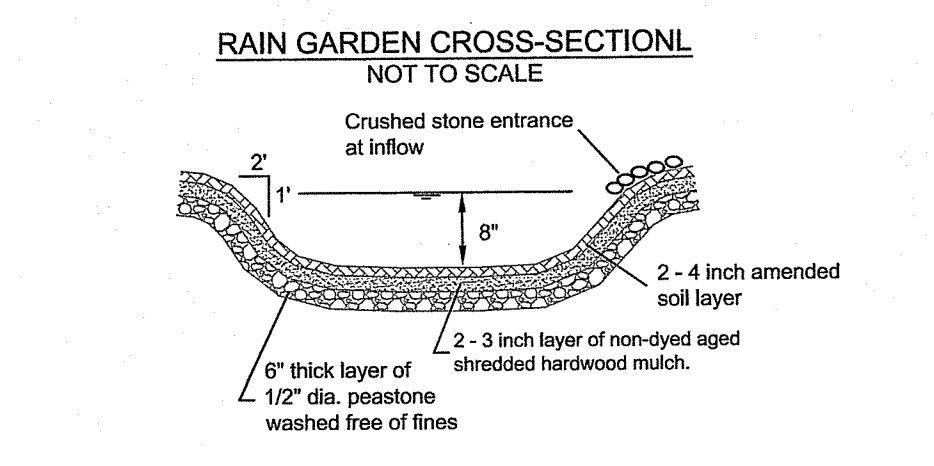

**RECIRCULATING EFFLUENT PUMP SYSTEM (REPS)**  
 (2 COMPARTMENT 2,000 GALLON SEPTIC TANK  
 AX 20 ADVANTEX TEXTILE FILTER)

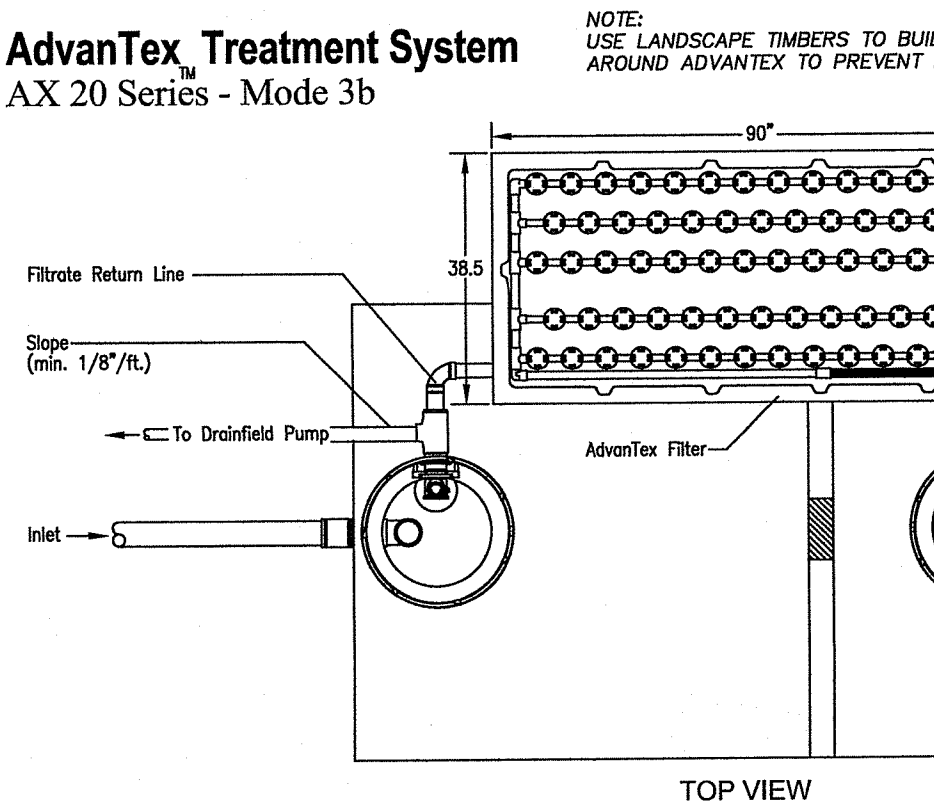

**RAIN GARDEN TREATMENT**

- Rain garden to be 8" deep with a 2-4 inch amended soil layer (50/50 mixture of the excavated native soils and mature organic compost) and a 2-3 inch layer of non-dyed aged shredded hardwood mulch.
- CONSTRUCTION**
1. A crushed stone entrance should be installed at the inflow to prevent channeling.
  2. A berm to detain stormwater should be constructed along the downhill side of the rain garden, perpendicular to the slope of the lawn
  3. Be sure that the soil within the rain garden area does not become compacted by construction activities (i.e. heavy machinery). If soil becomes severely compacted it may need to be tilled and amended to maintain proper

- MAINTENANCE**
1. The rain garden shall be inspected following at least the first two precipitation events of at least 1.0 inch to ensure that the system is functioning properly. Thereafter, the rain garden shall be monitored and maintained to assure proper functioning, plant growth and survival. Plants shall be replaced on an as-needed basis during the growing season.
  2. Silt/sediment shall be removed from the rain garden when the accumulation exceeds one inch, or when water ponds on the surface of the rain garden for more than 48 hours. The top few inches of material shall be removed and shall be replaced with fresh soil mixture and mulch.
  3. Pruning or replacement of woody vegetation shall occur when dead or dying vegetation is observed.
  4. Soil erosion gullies shall be repaired when they occur.
  5. Fertilizer or pesticides shall not be applied to plants within rain gardens.
  6. Perennial plants and ground covers shall be replaced as necessary to maintain an adequate vegetated ground cover. Annual plants may also be used to maintain ground cover.

**VEGETATED SWALE MAINTENANCE**

1. The vegetated swale shall be inspected annually and after large storm events.
2. Eroded side slopes and channel bottom shall be stabilized as necessary.
3. If the surface of the dry swale becomes clogged to the point that standing water is observed on the surface 48 hours after precipitation events, the bottom shall be top-dressed or cultivated to break up any hard-packed sediment, and then reseeded.
4. Vegetation in dry swales shall be mowed as required to maintain minimum grass heights in the 4-6 inch range.
5. Every five years, the channel bottom of dry swales should be scraped to remove sediment and to restore original cross section and infiltration rate, and should be seeded to restore ground cover, where necessary.

- SYSTEM COMPONENTS**
1. 2,000 GALLON 2-COMPARTMENT CONCRETE SEPTIC TANK WITH PUMP VAULT AND RECIRCULATING SPLITTER VALVE AND P5005 PUMP.
  2. 6" DEEP - 24" DIAMETER PUMP BASIN.
  3. AX-20 ADVANTEX TEXTILE FILTER.
  4. 20' LONG x 10' WIDE BOTTOMLESS SANDFILTER
  5. ORENCO SYSTEMS, INC. CONTROL PANEL.

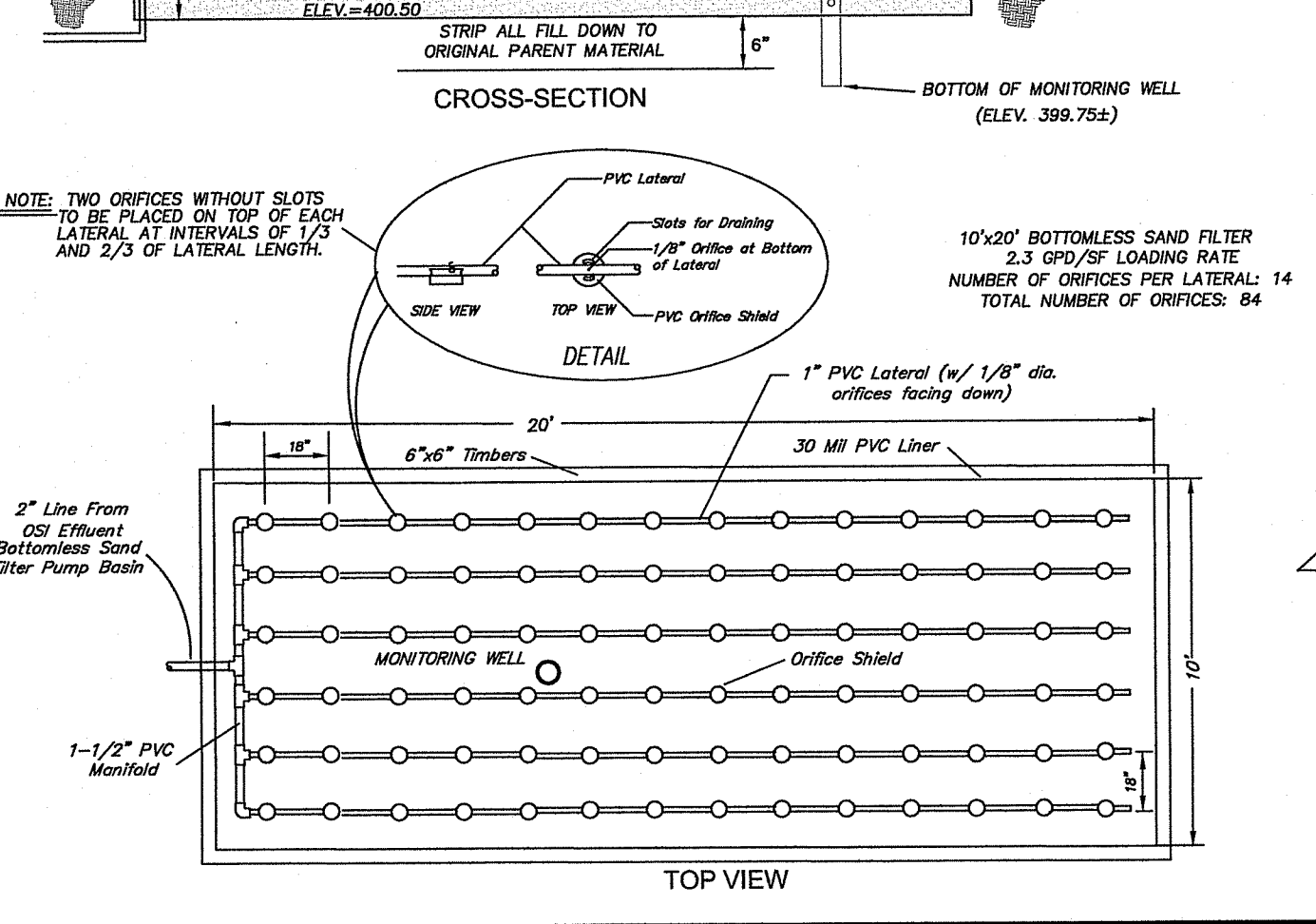
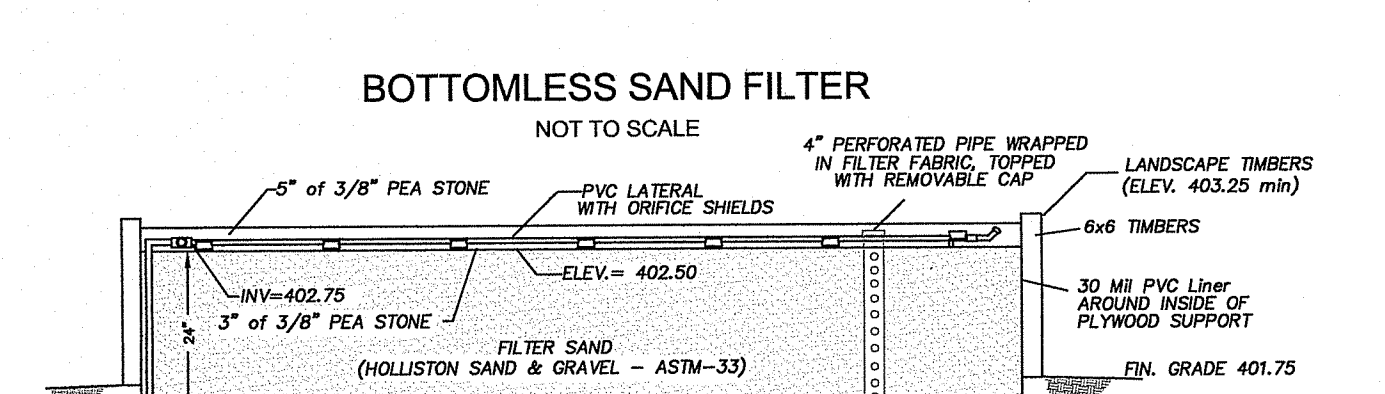

**TEST HOLE DATA**  
 DATE: 5-12-21

TH1	TH2
0'-6" Ap, SL, 10YR 2/2	0'-6" Ap, SL, 10YR 2/2
6'-30" Bw, SL, 10YR 5/6	6'-30" Bw, SL, 10YR 5/6
30'-96" C, CB, G, SL, 5YR 5/3	30'-96" C, CB, G, SL, 5YR 5/3
SHWT 18"	SHWT 18"
NO LEDGE AT 96"	NO LEDGE AT 96"
SOIL CATEGORY: 6	SOIL CATEGORY: 6

